



# R410A 60Hz Normal Efficiency Top-discharge Outdoor Series Service Manual

<b>Part 1 General information</b>	<b>5</b>
1. Model Names of Indoor/Outdoor Units	5
2. External Appearance	6
3. Features	8
<b>Part 2 Indoor Units</b>	<b>9</b>
1.Round-Way Cassette Type (Standard)	10
2.Duct Type	27
3.Ceiling & Floor Type	48
4.Air Handler unit	74
<b>Part 3 Outdoor Units</b>	<b>85</b>
1.Specification	86
2.Dimensions	87
3.Typical Installation	88
4.Wiring Diagrams	89
5.Electric Characteristics	91
6.Operation Limits	91
7. Exploded View	92
8.Sound Levels	94
9.Troubleshooting	95

**Part 4 Installation****101**

1. Precaution on Installation	102
2. Vacuum Dry and Leakage Checking	103
3. Additional Refrigerant Charge	105
4. Water Drainage	106
5. Insulation Work	109
6. Test Operation	111

**Part 5 Control****112**

1. Wireless Remote Controller	113
2. Wire Controller	118

# Part 1 General information

## 1. Model Names of Indoor/Outdoor Units

### 1.1 Indoor units





Model name	Dimension (W×H×D) (mm)	Net/Gross weight (kg)	Power supply
<b>Round-flow Cassette</b>			
<b>standard</b>			
CCR-24CR1	840×230×840	28/32	208~230V/1Ph/60Hz
CCR-36CR1	840×230×840	28/32	208~230V/1Ph/60Hz
CCR-48CR1	840×285×840	31/35	208~230V/1Ph/60Hz
CCR-60CR1	840×285×840	31/35	208~230V/1Ph/60Hz
<b>Medium ESP Ducted Type</b>			
CCACT24	1190×260×643	32/36	208~230V/1Ph/60Hz
CCACT36	1190×260×643	32/36	208~230V/1Ph/60Hz
CCACT48	1425×260×643	46/50	208~230V/1Ph/60Hz
CCACT60	1425×260×643	46/50	208~230V/1Ph/60Hz
<b>Ceiling&amp; Floor</b>			
CUAi-24CR1	1050×235×675	26.5/31	208~230V/1Ph/60Hz
CUAi-36CR1	1250×235×675	32/37	208~230V/1Ph/60Hz
CUAi-48CR1	1670×235×675	40/46	208~230V/1Ph/60Hz
CUAi-60CR1	1670×235×675	40/46	208~230V/1Ph/60Hz
<b>Air Handler units</b>			
CAHi-36CNR1	460x774x520	37/39	208~230V/1Ph/60Hz
CAHi-60CNR1	500x1160x550	45/48	208~230V/1Ph/60Hz

### 1.2 Outdoor Units

Model name	Dimension (W×D×H) (mm)	Net/Gross weight (kg)	Power supply
COT-24CNR1	554×554×633	46/49	208~230V/1Ph/60Hz
COT-36CNR1	554×554×633	46.5/49.5	208~230V/1Ph/60Hz
COT-48CNR1	740×740×835	92/96	208~230V/1Ph/60Hz
COT-48CXR1	740×740×835	81/88	208~230V/3Ph/60Hz
COT-60CNR1	740×740×835	89/94	208~230V/1Ph/60Hz
COT-60CXR1	740×740×835	81/88	208~230V/3Ph/60Hz

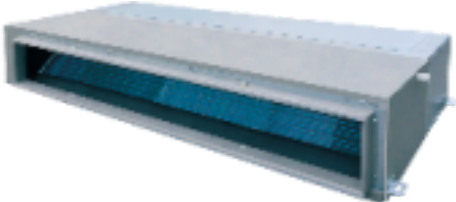
## 2. External Appearance

### 2.1 Indoor Units

<p><b>Round-way Cassette</b></p>  <p>24k~60k Btu/h</p>	
<p><b>Duct Type</b></p>	
 <p>Middle static pressure duct 24k/36kBtu/h</p>	 <p>Middle static pressure duct 48k/60kBtu/h</p>
<p><b>Ceiling&amp; Floor</b></p>	
 <p>24kBtu/h</p>	 <p>48k/60kBtu/h</p>
 <p>36kBtu/h</p>	
<p><b>Air Handler units</b></p>	



36kBTu/h



60kBTu/h

## 2.2 Outdoor units



24~36kBTu/h



48~60kBTu/h

### 3. Features

#### 3.1 High quality coils

The coil is constructed of advanced inner grooved copper tube and aluminum fins.



3.2 Low operation sound level: Well-known stable and quiet running fan motor.

3.3 Well-known compressor, GMCC & LG&Copeland.

3.4 Compact design: Smaller dimension and larger stuffing capacity.

3.5 Universal outdoor unit design.

## Part 2 Indoor Units

Round-Way Cassette Type	8
Duct Type	25
Ceiling & Floor Type	46
Air Handler units	72

## **1.Round-Way Cassette Type (Standard)**

<b>1. Features</b>	<b>9</b>
<b>2. Specifications</b>	<b>12</b>
<b>3. Dimensions</b>	<b>13</b>
<b>4. Service Space</b>	<b>14</b>
<b>5. Wiring Diagrams</b>	<b>15</b>
<b>6. Electric Characteristics</b>	<b>16</b>
<b>7. Sound Levels</b>	<b>16</b>
<b>8. Accessories</b>	<b>17</b>
<b>9. Exploded View</b>	<b>18</b>
<b>10. Field Wiring</b>	<b>20</b>
<b>11. Troubleshooting</b>	<b>21</b>

## 1.Features

- Brand-new panel design. Indoor unit use uniform panel, simple and convenient.  
Simple, featy and vogueish appearance suit for different requirements, it's mostly used for office, shopping center, restaurant, meeting room and etc.



- Ultra-thin body design, the min. height is only 230mm, save installation space.

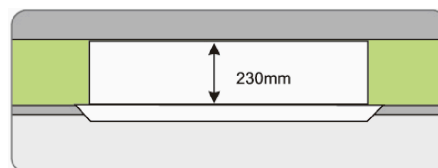

- Round way air flow, cool air can reach each corner of the room, providing comfortable environment.

- Intelligent auto-swing function, three modes for choice.

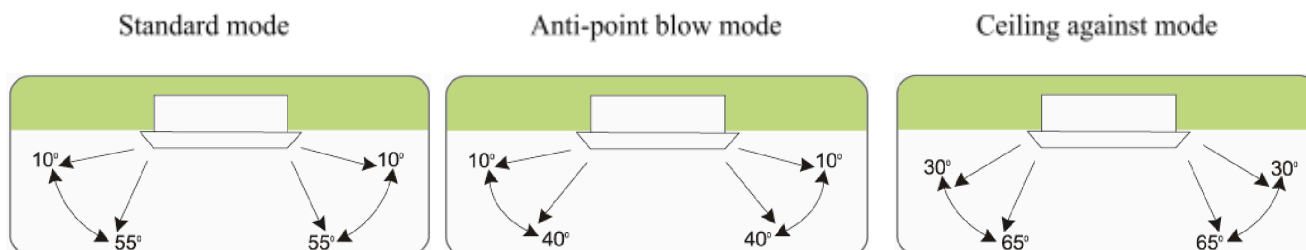

- 3-speed fan motor, meet for different requirements.

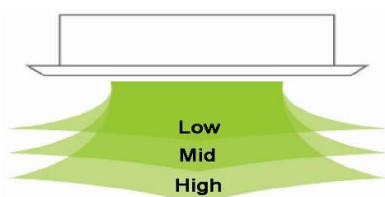

(6)New streamlined fan design.





6. Energy saving and healthy, adopting hydrophilic aluminum fins increasing heat-exchange efficiency.

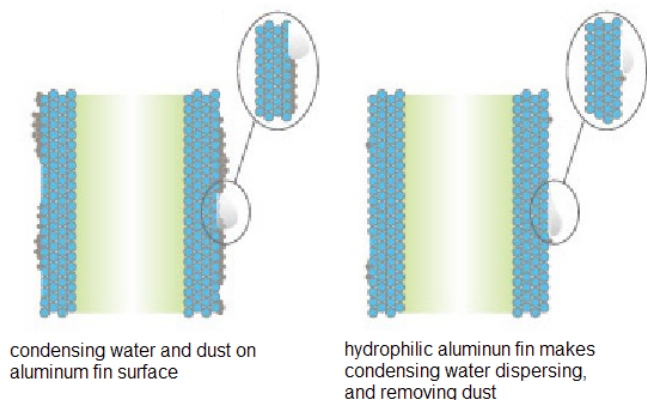

7. Easy and convenient installation and maintenance, washable filter design.

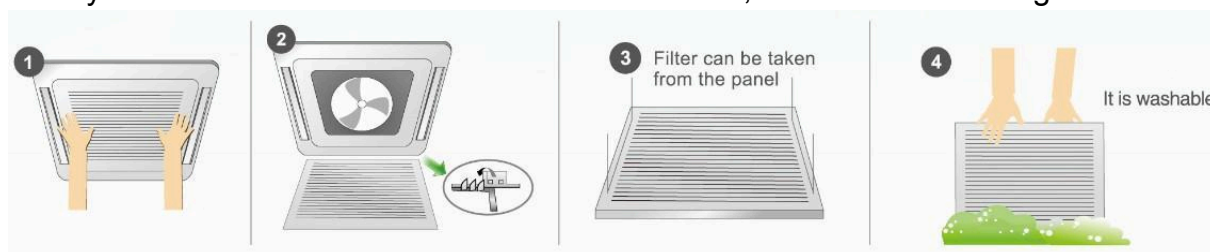

8. Built-in water pump, water head up to 1200mm (Compact type, 700mm).

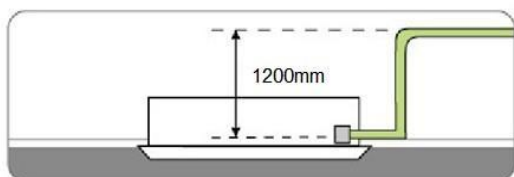

9. Fire resistance design, the E-box with galvanized steel built-in body easy for maintenance.



10. Add 4 interfaces in body, can be connected with duct to another room. Fresh air makes air quality more healthy and comfortable.



11. Multi protection and auto-restart function.

12. Standard for wireless controller; option for wired controller.



Standard

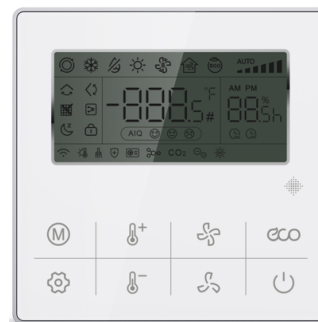

optional

## 2. Specifications

Model		CCR-24CR1	CCR-36CR1	CCR-48CR1	CCR-60CR1	
Code		821028300040	821028900052	821029700042	821030100026	
Indoor power supply		V/Ph/H z	208~230/1/60	208~230/1/60	208~230/1/60	
Cooling	Capacity	Btu/h	24000	36000	48000	60000
		W	7032	10548	14064	17580
	Input	W	2733	4125	5566	6912
	Rated current	A	11.1	17.5	25.84	29.23
	Input(Indoor unit)	W	150	150	180	180
	Rated current(Indoor unit)	A	0.7	0.7	0.8	0.8
EER	W/W	2.57	2.56	2.53	2.54	
Indoor fan motor	Brand		Kaibang	Kaibang	Kaibang	Kaibang
	Model		YDK-45Q-8P2	YDK-45Q-8P2	YDK-80Q-8P2	YDK-80Q-8P2
	Input	W	102	102	160	160
	Capacitor	μF	2.5	2.5	4	4
	Speed(Hi/Me/Lo)	r/min	850/730/580	850/730/580	800/750/650	800/750/650
Indoor coil	Number of rows		2	2	2	2
	Tube pitch(a)xrow pitch(b)	mm	21×13.37	21×13.37	21×13.37	21×13.37
	Fin spacing	mm	1.45	1.45	1.45	1.45
	Fin type		Hydrophilic	Hydrophilic	Hydrophilic	Hydrophilic
	Tube outside dia. and type	mm	Φ7	Φ7	Φ7	Φ7
			inner grooved	inner grooved	inner grooved	inner grooved
Number of circuits		8	8	12	12	
Indoor air flow(High speed)		m <sup>3</sup> /h	1200	1200	1900	1900
Indoor noise level		dB(A)	45~52	45~52	51~57	51~57
Indoor unit	Dimension(W*D*H)	Body (mm)	840×840×230	840×840×230	840×840×285	840×840×285
		Panel (mm)	950×950×50	950×950×50	950×950×50	950×950×50
	Packing(W*D*H)	Body (mm)	920×920×310	920×920×310	920×920×375	920×920×375
		Panel (mm)	1030×1030×10 5	1030×1030×10 5	1030×1030×10 5	1030×1030×10 5
	Net/Gross weight	Body /Kg	28/32	28/32	31/35	31/35
		Panel /Kg	5.4/8.0	5.4/8.0	5.4/8.0	5.4/8.0
Max pressure		MPa	4.0	4.0	4.5	4.5
Refrigerant type			R410A	R410A	R410A	R410A
Refrigerant piping	Liquid side/Gas side	mm	Φ9.52/Φ15.88	Φ9.52/Φ19.05	Φ9.52/Φ19.05	Φ9.52/Φ19.05
Drainage pipe		mm	25	25	25	25
Standard controller						
Operation temp		°C	16~32	16~32	16~32	16~32
Ambient temp		°C	18~43	18~43	18~43	18~43
Application area		m <sup>2</sup>	28-50	40-70	55~95	60~105
Stuffing Quantity(20'/40'/40'HQ)		set	75/155/170	65/130/150	65/130/150	65/130/150

**Notes:** 1. Nominal cooling capacities are based on the following conditions:

Indoor temp: 27°CDB, 19°CWB; Outdoor temp: 35°CDB; Equivalent ref. piping: 7.5m (horizontal)

2. Nominal heating capacities are based on the following conditions:

Indoor temp: 20°CDB; Outdoor temp: 7°CDB, 6°CWB; Equivalent ref. piping: 7.5m (horizontal)

3. Actual noise level may differ, depending on the room structure, etc, since these noise values are from an anechoic room.

### 3. Dimensions

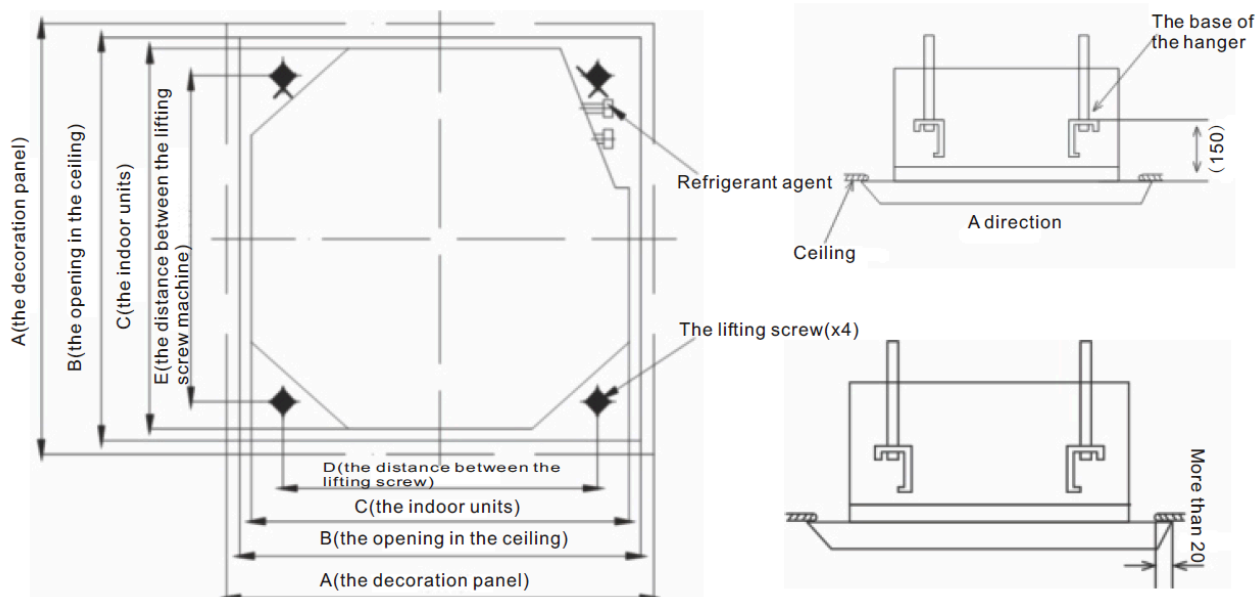

Installation dimension unit: mm

Model (kBtu/h)	Dimensions(H)
For 18, 24 series	230
For 36, 48, 60 series	285

unit: mm

Model (kBtu/h)	Dimensions(H)				
	A	B	C	D	E
For 18, 24, 36, 48, 60 series	950	890*	840	680	780

#### 4. Service Space

The indoor unit should be installed in a location that meets the following requirements:

- There is enough room for installation and maintenance.
- The ceiling is horizontal, and its structure can endure the weight of the indoor unit.
- The outlet and the inlet are not impeded, and the influence of external air is the least.
- The air flow can reach throughout the room.
- The connecting pipe and drainpipe could be extracted out easily.
- There is no direct radiation from heaters.

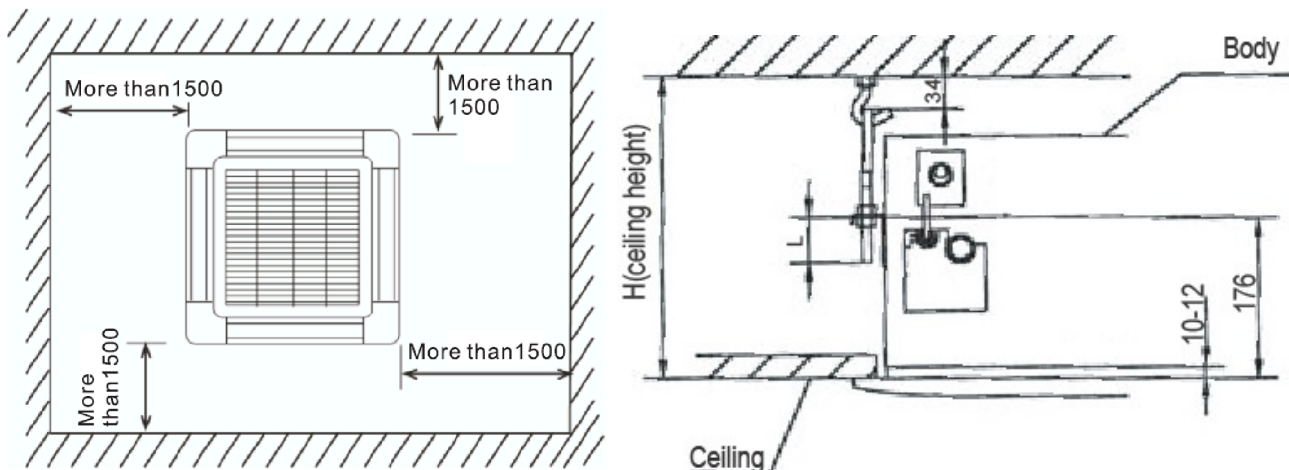

## 5. Wiring Diagrams

### 24K/36K

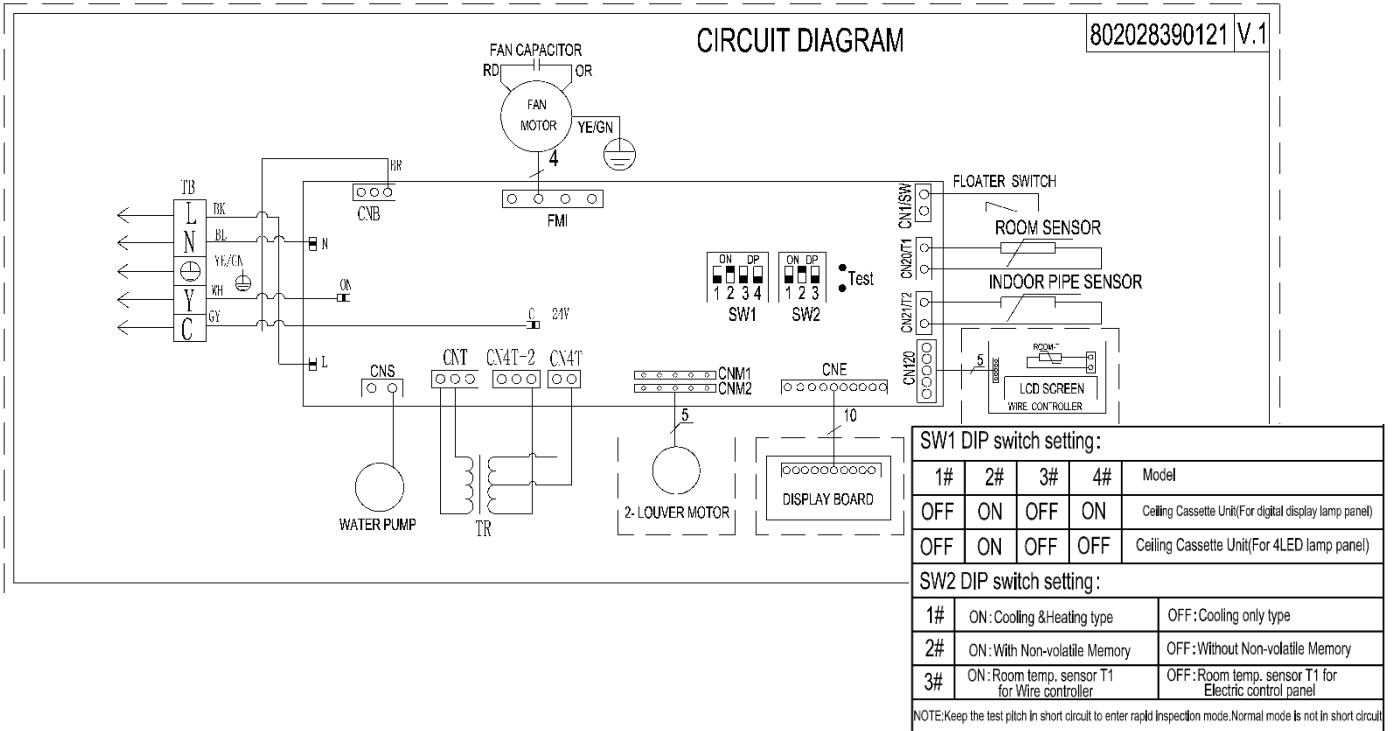

### 48K/60K

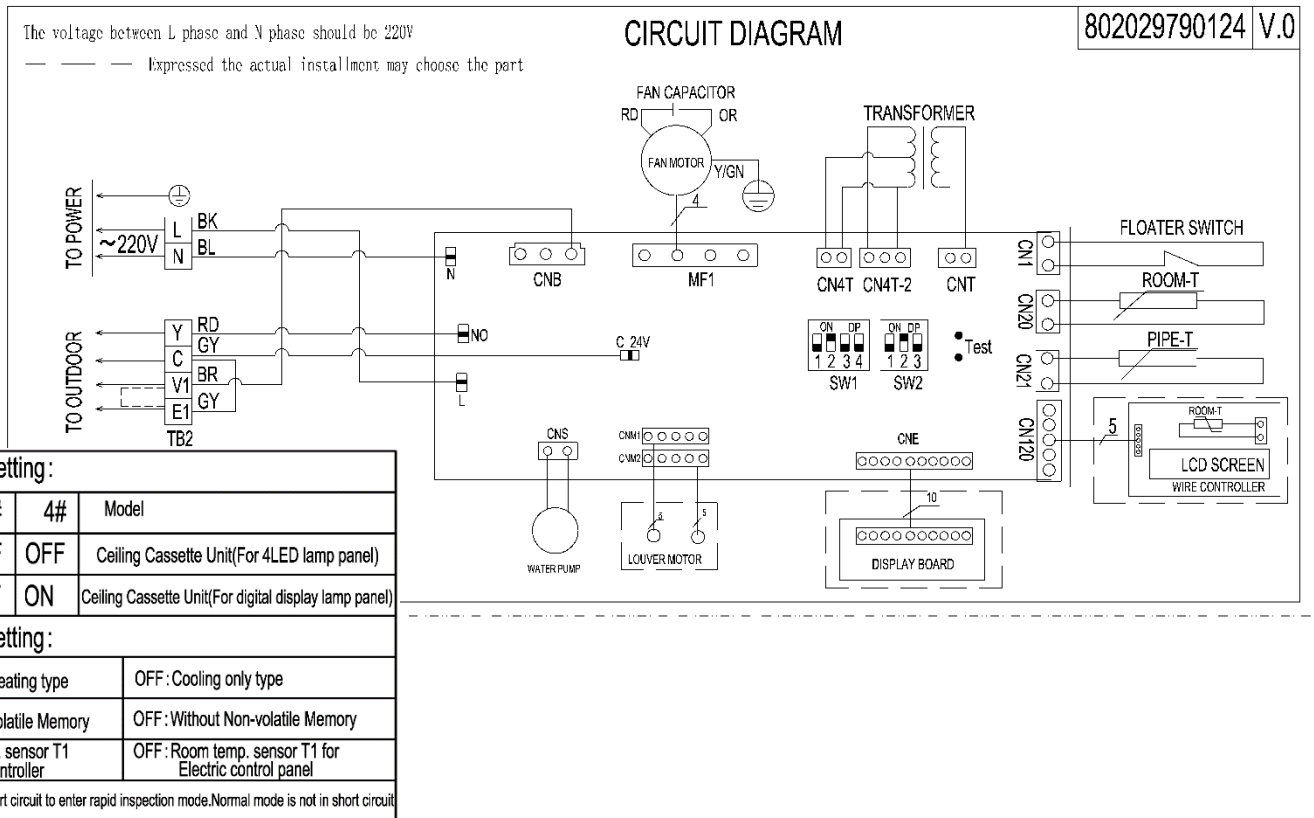



## 6. Electric Characteristics

Model	Indoor Unit			
	Hz	Voltage	Min.	Max.
CCA-24CR1	60	208-230V	187V	244V
CCA-36CR1	60	208-230V	187V	244V
CCA-48CR1	60	208-230V	187V	244V
CCA-60CR1	60	208-230V	187V	244V

Remark:

MCA: Min. Current Amps. (A)

MFA: Max. Fuse Amps. (A)













## 7. Sound Levels



Model	Noise level dB(A)		
	H	M	L
CCA-24CR1	52	48	45
CCA-36CR1	52	48	45
CCA-48CR1	57	54	51
CCA-60CR1	57	54	51



## 8. Accessories

	Name	Shape	Quantity
Installation Fittings	1. Expansible hook		4
	2. Installation hook		4
	3. Installation paper board		1
	4. Bolt M5		4
Tubing & Fittings	5. Connecting pipe group		1
	6. Binding tape		1
	7. Soundproof/insulation sheath		2
Drainpipe Fittings	8. Out-let pipe sheath		1
	10. Tightening band		5
Protect Pipe Fittings	13. Wall conduit		1
	14. Wall conduit cover		1
Remote controller	15. Remote controller		1
	16. Mounting screw(ST2.9×10-C-H)		2
	17. Alkaline dry batteries (AM4)		2

### 9. Exploded View

CCA-24CR1 CCA-36CR1 CCA-48CR1 CCA-60CR1

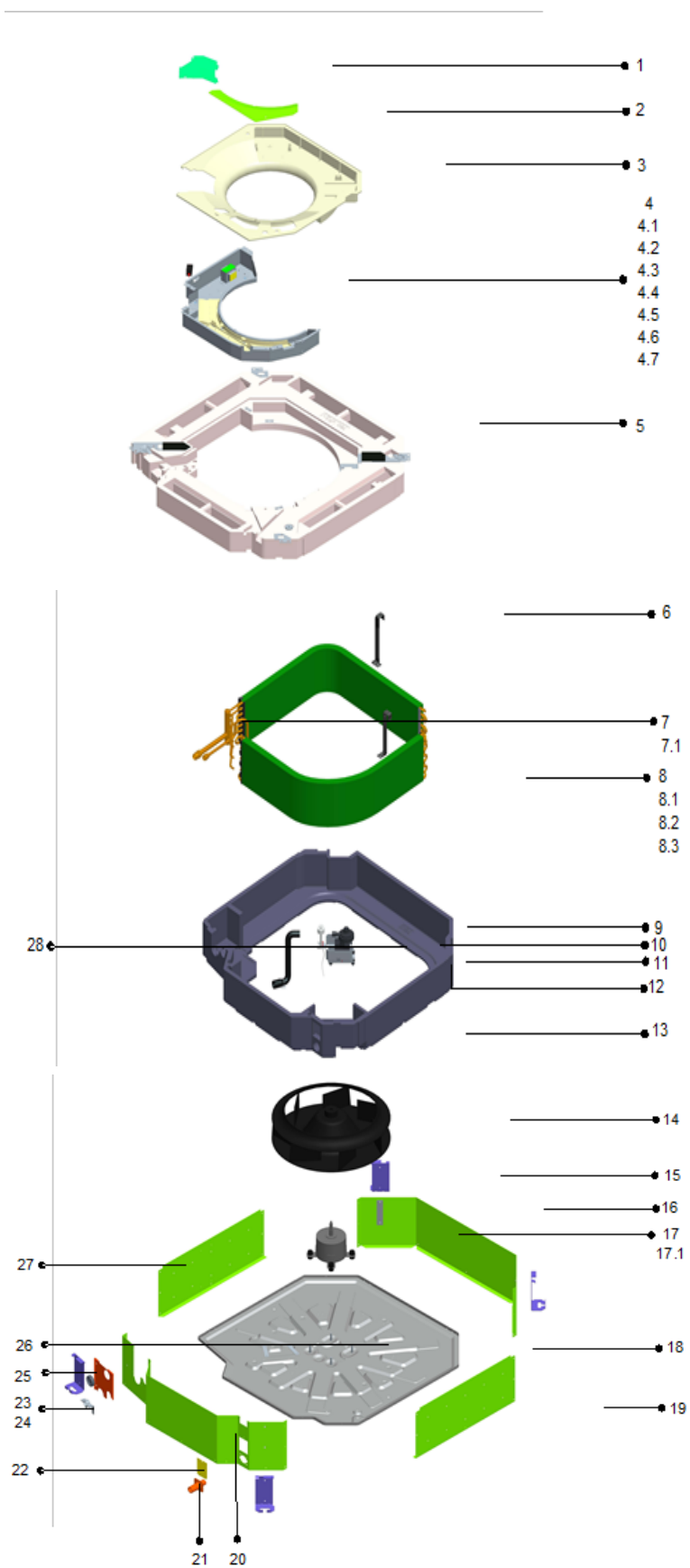

No.	Part Name	Quantity	No.	Part Name	Quantity
1	Warning panel	1	8.3.4	Instalation tube for probe	1
2	Circuit diagram panel	1	9	Water pump	1
3	Small wind inlet guide	1	10	Liquid-level sensor	1
4	E-parts components	1	11	Water pump fan motor holder	1
4.1	E-parts box welding assy	1	12	Underlay for water pump support	3
4.2	No.3 groove clamp	1	13	Upper foam	1
4.3	(ROHS)Transformer	1	14	Centrifugal fan	1
4.4	Fan motor capacitor	1	15	Hanger	4
4.5	Terminal (DJ-75W-3PA)	1	16	Rear brattice	1
4.6	Terminal (DJ-75W-5PA)	1	17	Fan motor for indoor unit (YDK-55T-6)	1
4.7	Electric control board for indoor unit	1	17.1	Fan motor foot underlay	1
4.8	E-parts box	1	18	Chassis assy	1
5	Water pan assy	1	19	Right clapboard	1
6	Auxiliary fixing board for evaporator	2	20	Front brattice	1
7	Main fixing board assy	1	21	Discharge pipe joint	1
7.1	Main fixing board for evaporator	1	22	Side maintenance board for water pump	1
8	Evaporator components	1	23	Lower clamp	1
8.1	Rubber insulating pipe	1	24	Upper clamp	1
8.2	Insulating pipe	1	25	Valve panel	1
8.3	Welding parts for evaporator	1	26	Wire board	2
8.3.1	Collecting pipe assy for evaporator	1	27	Left clapboard	1
8.3.2	Distributing pipe assy for evaporator	1	28	Water outlet pipe	1
8.3.3	Evaporator	1			

### 10. Field Wiring

CCA-24C CCA-36C

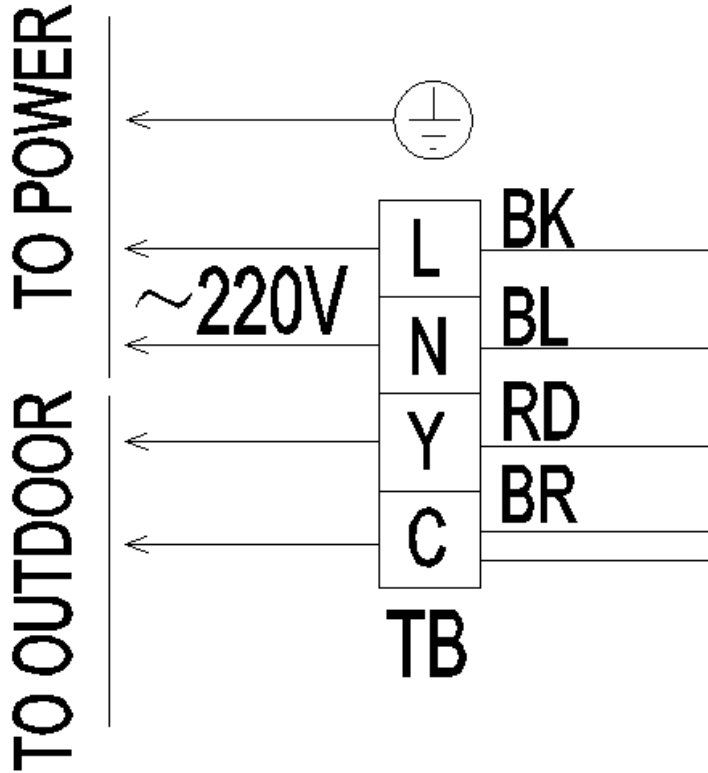

CCA-48C CCA-60C

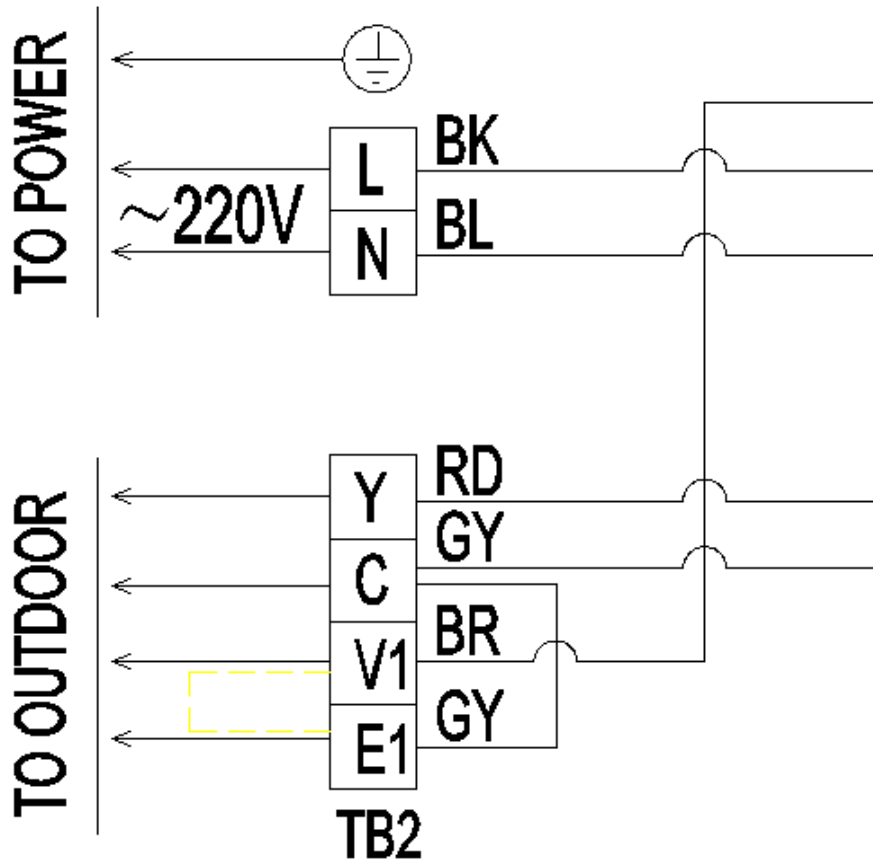

## 11. Troubleshooting

Fault Code Table

<b>4LED Faults</b>	<b>Digital display</b>	<b>Failure description</b>
Timer light flashing	E2	Ambient temperature sensor (T1) failure
Running light flashing	E3	Evaporator pipe temperature sensor (T2) failure
Defrost light flashing	E5	Condenser pipe temperature sensor (T3) failure
Warning light flashing	F5	Water fullfilled protection
Running light, defrost light flashing	E1	Indoor unit and wire controller communication failure
Running light, timer light flashing	P6	Indoor unit EEPROM failure
Defrost light, timer light flashing	F0	Indoor fan stall protection
Defrost light, warning light flashing	F2	Outdoor protection
	F7	outdoor unit over-current protection
Timer light, warning light flashing	E0	Indoor unit and outdoor unit communication failure
Running light, defrost light, timer light flashing	F3	High pressure protection
Defrost light, timer light, warning light flashing	F4	Low pressure protection
Running light, timer light, warning light flashing	F8	Outdoor unit exhaust temperature over-high protection
Running light, defrost light, timer light, warning light flashing	F9	Three-phase electricity phase sequence failure
Note: the flashing frequency for all above indication lights is 1HZ.		

**E2: Indoor ambient temp. sensor fault (T1 sensor)**

Solution:

- (1) Check the T1 sensor connection loosen or not, inset it firmly, if not solve, go to next step;
- (2) Take out the sensor, measure the resistance of the sensor, it is about  $5K\Omega$  at  $25^{\circ}C$ , if not, replace it; if resistance normally, change the indoor main board.

**E3: Indoor evaporator pipe temperature sensor (T2) failure**

Solution:

- (1) Check the T2 sensor connection loosen or not, inset it firmly, if not solve, go to next step;
- (2) Take out the sensor, measure the resistance of the sensor, it is about  $5K\Omega$  at  $25^{\circ}C$ , if not, replace it; if resistance normally, change the indoor main board

**E5: Condenser pipe temperature sensor (T3) failure**

Solution:

- (1) Check the T3 sensor connection loosen or not, inset it firmly, if not solve, go to next step;
- (2) Take out the sensor, measure the resistance of the sensor, it is about  $5K\Omega$  at  $25^{\circ}C$ , if not, replace it; if resistance normally, change the main board

**F2: Outdoor unit protection**

Solution:

Follow the F3/F4/F8/F9.

**F3: High pressure protection**

Solution:

- (1) If the unit does not have high pressure switch, change the outdoor main board; if it has, go to next step
- (2) Take out the high-pressure switch, measure its resistance, it is about  $0\Omega$ , if not, replace it; otherwise go to next step;
- (3) Short connect the high-pressure switch port on the outdoor board, if it still shows P1, replace the outdoor main board; otherwise go to next step;
- (4) Connect the pressure gauge to test the high pressure, if it is real too high, may be cause by too much refrigerant or other gas getting inside the system

**F4: Low pressure protection**

Solution:

- (1) If the unit does not have low pressure switch, change the outdoor main board; if it has, go to next step
- (2) Take out the low-pressure switch, measure its resistance, confirm whether it is about  $0\Omega$ , if not, replace it; otherwise go to next step;
- (3) Short connect the low-pressure switch port on the outdoor board, if it still shows P2, replace the outdoor main board; otherwise go to next step;
- (4) Connect the pressure gauge to test the low pressure, if it is real too low, may be cause by lack of refrigerant or leakage in the refrigerant system

**F5: Water fulfilled protection (Alarm of condensing water overflow)**

Solution:

- (1) If the unit does not have water drainage pump:
  - a) Check the water level switch short connect or not, if not, short connect it, if it still not solves, change the main board
- (2) If the unit has water drainage pump:
  - a) Check the water level switch if it is connected well, inset it firmly; then check the switch is blocked or not, if it is blocked, replace it, otherwise go to next step
  - b) Check the connection between pump and main board if it is 220-240V, if it is, change the water pump; if not, change the indoor main board

**F7: Outdoor overcurrent protection**

Solution:

- (1) Check the dial-switches is setting corrected or not according to the wiring diagram, if not, set it corrected; if corrected, go to next step
- (2) Check the condenser whether it is in good ventilation, if not, remove the blockage; otherwise go to the next step.
- (3) Measure the current with multimeter, and check the current via the unit check data also, compare these two data, if they are quite different, change the outdoor main board;
- (4) If all above steps done normally, it may be caused damaged compressor or refrigerant system blocked or dirty or other gas get inside the system

### **F8: Outdoor unit exhaust temperature over-high protection**

Solution:

- (1) Check the T5 sensor connection loosen or not, inset it firmly, if not solve, go to next step;
- (2) Take out the exhaust sensor (T5) from main board, measure its resistance, it is about 50K $\Omega$  at 25 $^{\circ}$ C, if not, change the sensor; if it is, go to next step
- (3) Remove the sensor from the compressor, if it still not solves, change the main board
- (4) If all above steps done normally, it may be caused lack of refrigerant or damaged compressor or refrigerant system blocked or dirty or other gas get inside the system.

### **F9: Three-phase electricity power phase sequence failure**

Solution:

- (1) Check the 3-phase power connection lines are connected well or not
- (2) Using the meter to measure the voltage (L1&N, L2&N, L3&N), all of them should be 220V, if not, correct the power supply, otherwise go to next step;
- (3) If the power supply is corrected, change the main board

### **P6: EEPROM failure**

Change the indoor mainboard

## 2.Duct Type

### Middle Static Pressure-Duct Type

1.Features	25
2.Specifications	27
3.Dimensions	28
4.Service Space	29
5. Wiring Diagrams	30
6. Capacity Tables	31
7. Capacity Correction Factors	33
8. Static Pressure	34
9. Electric Characteristics	35
10. Sound Levels	36
11. Accessories	37
12. The Specification of Power	38
13. Exploded views	39
14. Field Wiring	40
14. Troubleshooting	41



## 1. Features:

1.Ultra-thin body design.

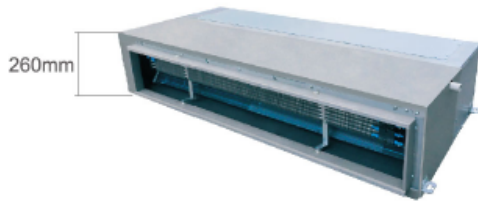

Medium ESP Type

2.Adopting aviation centrifugal fans,and CFD technology design,increasing air-volume and decreasing noise level.

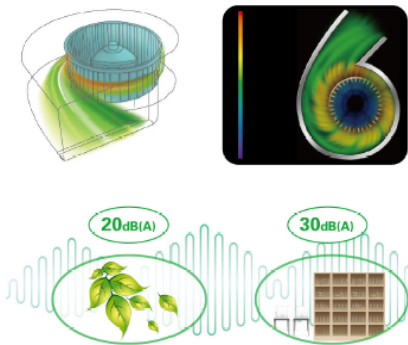

3. Filter can be taken out easily for clean maintenance.

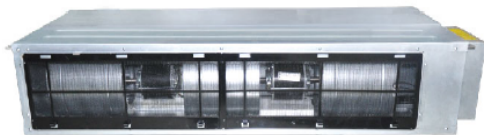

4. Body-side is E-box,convenient for installation and maintenance.



5.Three fan speed,meeting different requirements.



6.30Pa ESP design, duct connected installation meeting different room structure.

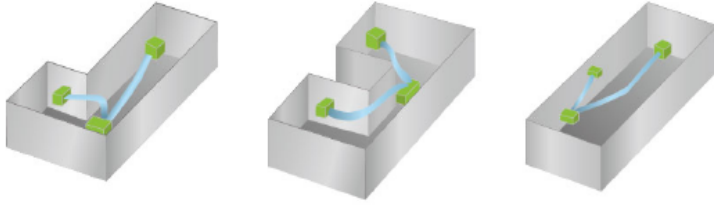

4. Multi protection and auto-restart function.

## 2. Specifications

Model (Duct Indoor Unit)			CCACT24	CCACT36	CCACT48	CCACT60
Power supply		V/Ph/Hz	220/1/60	220/1/60	220/1/60	220/1/60
Cooling	Capacity	Btu/h	24000	36000	48000	60000
	Capacity	W	7034	10551	14068	17585
	Input	W	3430	3620	6519	7250
	Rated current	A	15.3	15.3	13.8	43
	EER	Btu/h.W	7.00	9.94	7.36	8.28
	EER	W/W	2.05	2.91	2.16	2.43
Max. input consumption		W	210	260	370	340
Max. current		A	1.8	2.1	1.8	1.8
Indoor external static pressure		pa	30	30	30	30
Starting current		A	42	50	80	98
Operation Control		\	wired	wired	wired	wired
Indoor coil	Number of rows		3	3	3	3
	Tube pitch(a)xrow pitch(b)	mm	22×19.05	22×19.05	22×19.05	22×19.05
	Fin spacing	mm	1.7	1.7	1.7	1.7
	Fin type		Hydrophilic	Hydrophilic	Hydrophilic	Hydrophilic
	Tube outside dia. and type	mm	Φ7.94	Φ7.94	Φ7.94	Φ7.94
			inner grooved	inner grooved	inner grooved	inner grooved
Number of circuits		6	6	6	6	
Indoor air flow(High speed)		m³/h	1150	1300	2000	2000
Static Pressure		Pa	30	30	30	30
Indoor noise level		dB(A)	40~52	45~50	51~56	51~56
Indoor unit	Dimension(W*H*D)	Body(mm)	1190×260×643	1190×260×643	1425×260×643	1425×260×643
	Packing(W*H*D)	Body(mm)	1255×325×720	1255×325×720	1490×325×720	1490×325×720
	Net/Gross weight		Body(Kg)	32/36	32/36	46/50
Max pressure		MPa	4.0	4.0	4.5	3.8
Refrigerant type			R410A	R410A	R410A	R410A
Refrigerant piping	Liquid side/Gas side	mm	Φ9.52/Φ15.88	Φ9.52/Φ19.05	Φ9.52/Φ19.05	Φ9.52/Φ19.05
Drainage pipe		mm	30	30	30	30
Operation temp		°C	16~32	16~32	16~32	16~32
Ambient temp		°C	-7~43	-7~43	-7~43	-7~43
Application area		m²	28-50	40-70	55-95	60-105
Stuffing Quantity(20'/40'/40'HQ)		set	90/168/162	75/168/180	75/168/180	75/168/180

- Notes:**
- Nominal cooling capacities are based on the following conditions:  
Indoor temp: 27°CDB, 19°CWB; Outdoor temp: 35°CDB; Equivalent ref. piping: 7.5m (horizontal);
  - Nominal heating capacities are based on the following conditions:  
Indoor temp: 20°CDB; Outdoor temp: 7°CDB, 6°CWB; Equivalent ref. piping: 7.5m (horizontal)
  - Actual noise level may differ, depending on the room structure, etc, since these noise values are from an anechoic room.

### 3. Dimensions

CCACT24 CCACT36 CCACT48 CCACT60

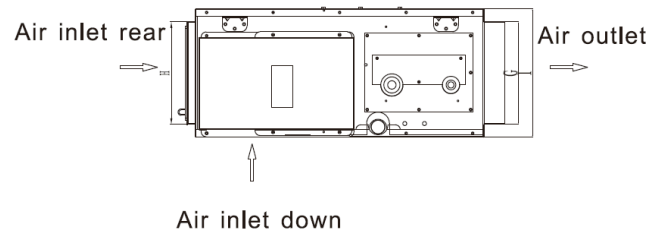
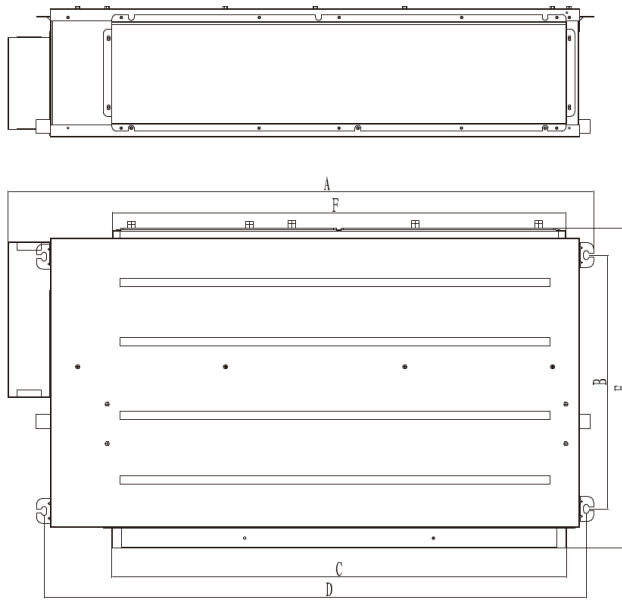

Model KBtu/h	A	B	C	D	E	F	G	H	I
24,36	1190	515	920	1100	643	920	207	207	260
48,60	1425	515	1155	1337	643	1155	207	207	260

## 4. Service Space

Ensure enough space required for installation and maintenance.

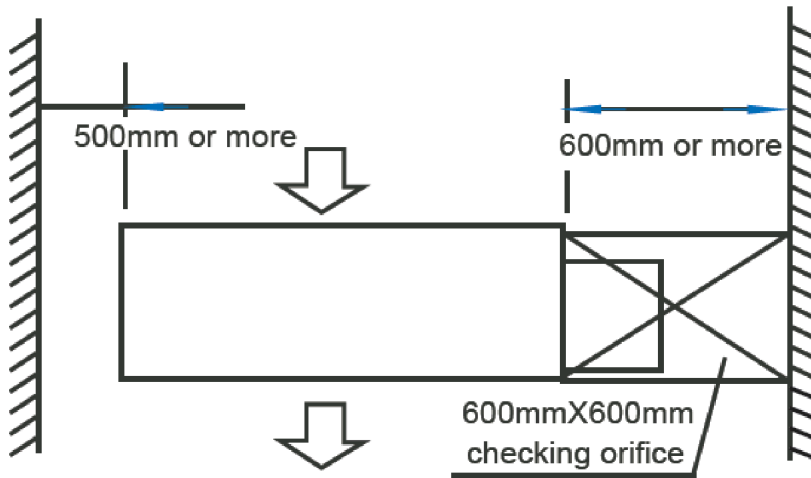

There is enough space for installation and maintenance. The ceiling is horizontal, and its structure can endure the weight of the indoor unit. The outlet and the inlet are not impeded, and the influence of external air is the least. The air flow can reach throughout the room. The connecting pipe and drainpipe could be extracted out easily. There is no direct radiation from heater.

## 5. Wiring Diagrams

### CCACT24 CCACT36

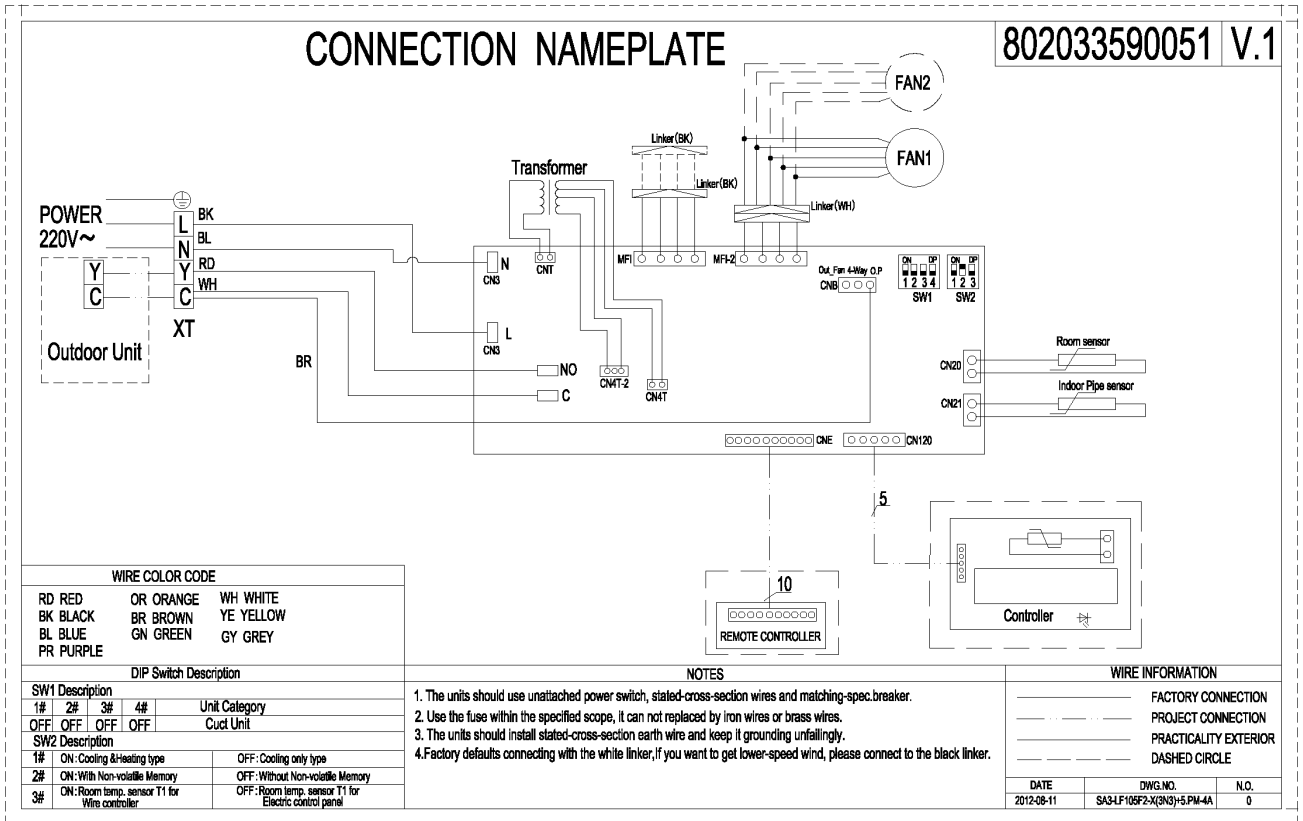

### CCACT48 CCACT60

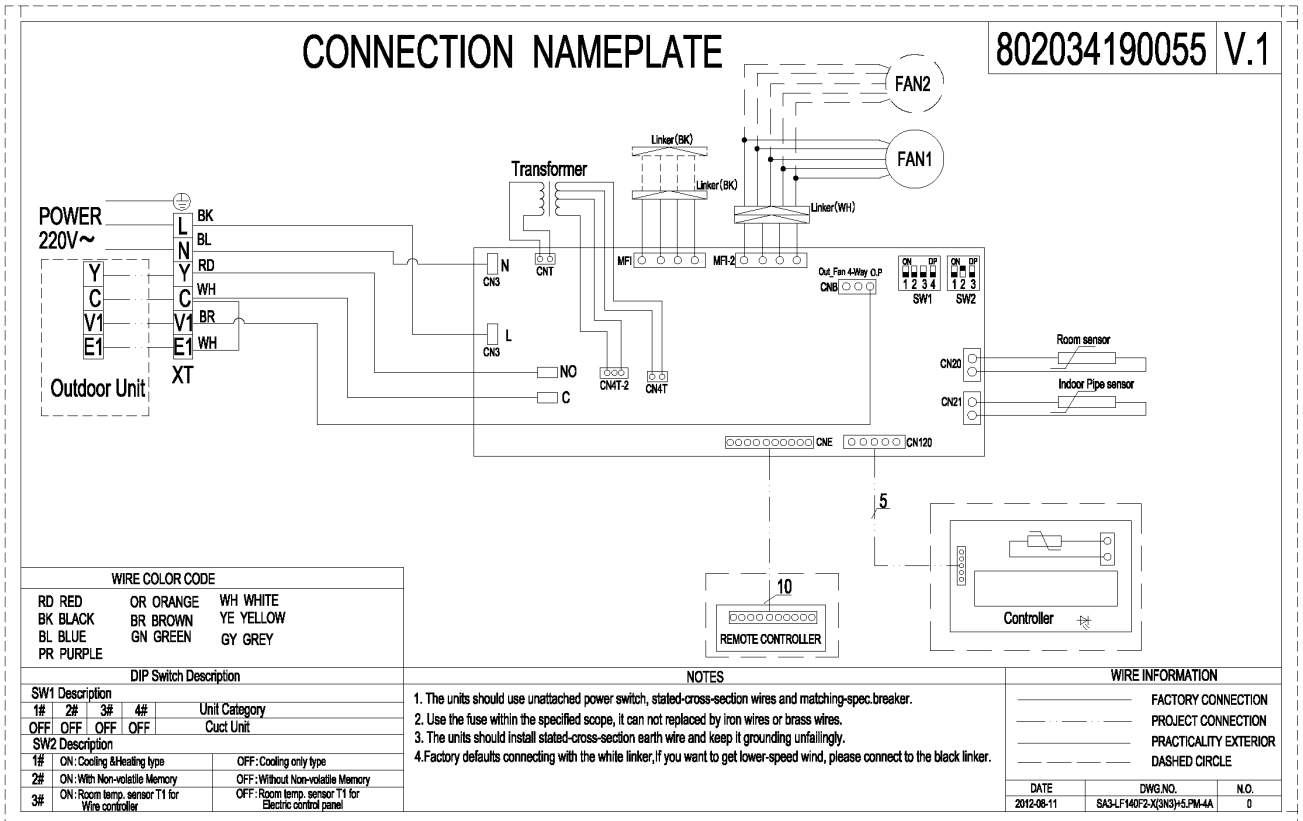

## 6. Capacity Tables

### 6.1 Cooling Capacity

#### CCACT24

Cooling		Outdoor conditions (DB)			
Indoor Conditions	(kW)	21°C	28°C	35°C	43°C
21/15°C DB/WB	TC	6.78	6.43	6.08	5.80
	SC	5.03	4.97	4.90	4.92
	Input	1.93	2.12	2.22	2.30
24/17°C DB/WB	TC	7.12	6.77	6.42	6.00
	SC	5.25	5.21	5.13	4.98
	Input	2.07	2.22	2.32	2.45
27/19°C DB/WB	TC	7.26	6.91	<b>6.70</b>	6.21
	SC	5.29	5.25	5.15	5.03
	Input	2.12	2.25	<b>2.39</b>	2.51
32/23°C DB/WB	TC	7.40	7.12	6.98	6.42
	SC	6.24	6.15	6.10	5.94
	Input	2.22	2.32	2.51	2.61

#### CCACT36

Cooling		Outdoor conditions (DB)			
Indoor Conditions	(kW)	21°C	28°C	35°C	43°C
21/15°C DB/WB	TC	10.12	9.59	9.07	8.65
	SC	7.50	7.42	7.31	7.35
	Input	2.88	3.17	3.32	3.44
24/17°C DB/WB	TC	10.63	10.11	9.58	8.95
	SC	7.83	7.77	7.66	7.44
	Input	3.09	3.32	3.47	3.66
27/19°C DB/WB	TC	10.84	10.32	<b>10.00</b>	9.27
	SC	7.89	7.83	7.69	7.51
	Input	3.17	3.36	<b>3.57</b>	3.74
32/23°C DB/WB	TC	11.05	10.63	10.42	9.58
	SC	9.32	9.18	9.11	8.87
	Input	3.32	3.47	3.74	3.89

#### CCACT48

Cooling		Outdoor conditions (DB)			
Indoor Conditions	(kW)	21°C	28°C	35°C	43°C
21/15°C DB/WB	TC	14.42	13.72	13.02	12.46
	SC	10.67	10.56	10.42	10.47
	Input	4.33	4.70	4.91	5.06
24/17°C DB/WB	TC	14.84	14.14	13.44	12.60
	SC	11.13	11.03	10.89	10.58
	Input	4.59	4.91	5.12	5.38
27/19°C DB/WB	TC	15.12	14.42	<b>14.00</b>	13.02
	SC	11.19	11.10	10.92	10.68
	Input	4.70	4.96	<b>5.23</b>	5.48
32/23°C DB/WB	TC	15.40	14.84	14.56	13.44
	SC	13.09	12.91	12.81	12.50
	Input	4.91	5.12	5.93	6.04

**CCACT60**

Cooling		Outdoor conditions (DB)			
Indoor Conditions	(kW)	21°C	28°C	35°C	43°C
21/15°C DB/WB	TC	16.44	15.64	14.84	14.20
	SC	12.16	12.04	11.88	11.94
	Input	4.94	5.36	5.60	5.77
24/17°C DB/WB	TC	16.92	16.12	15.32	14.36
	SC	12.69	12.57	12.41	12.06
	Input	5.23	5.60	5.84	6.13
27/19°C DB/WB	TC	17.24	16.44	<b>15.96</b>	14.84
	SC	12.76	12.65	12.45	12.18
	Input	5.36	5.65	<b>5.96</b>	6.25
32/23°C DB/WB	TC	17.56	16.92	16.60	15.32
	SC	14.92	14.72	14.60	14.25
	Input	5.60	5.84	6.76	6.89

**Remark:**

TC : Total capacity ; kW

SC: Sensible heat capacity ; kW

Input: Input power; kW



## 7. Capacity Correction Factors

### 7.1 Correction factor of the length and elevation difference of refrigerant pipe

#### (1) Rate of change in cooling capacity

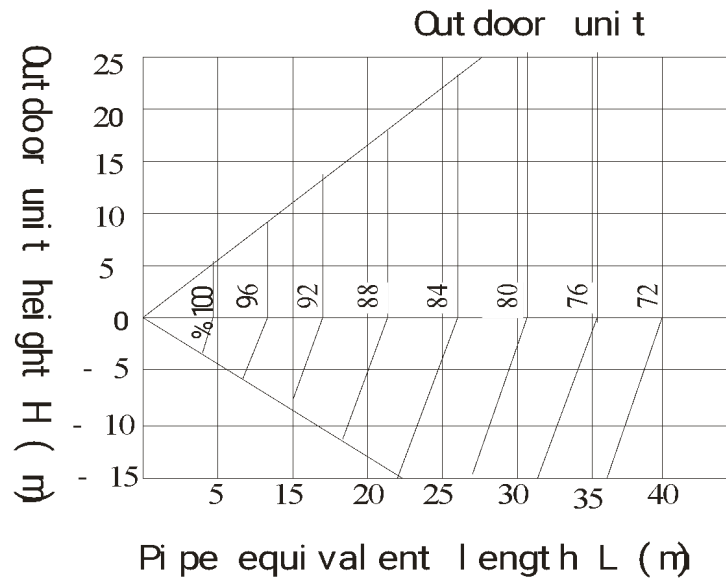

#### (2) Rate of change in heating capacity

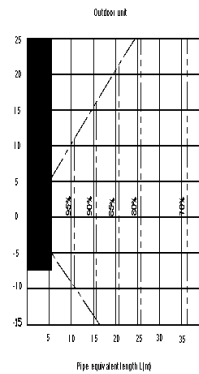

## 8. Static Pressure

CCACT24 CCACT36 CCACT48 CCACT60

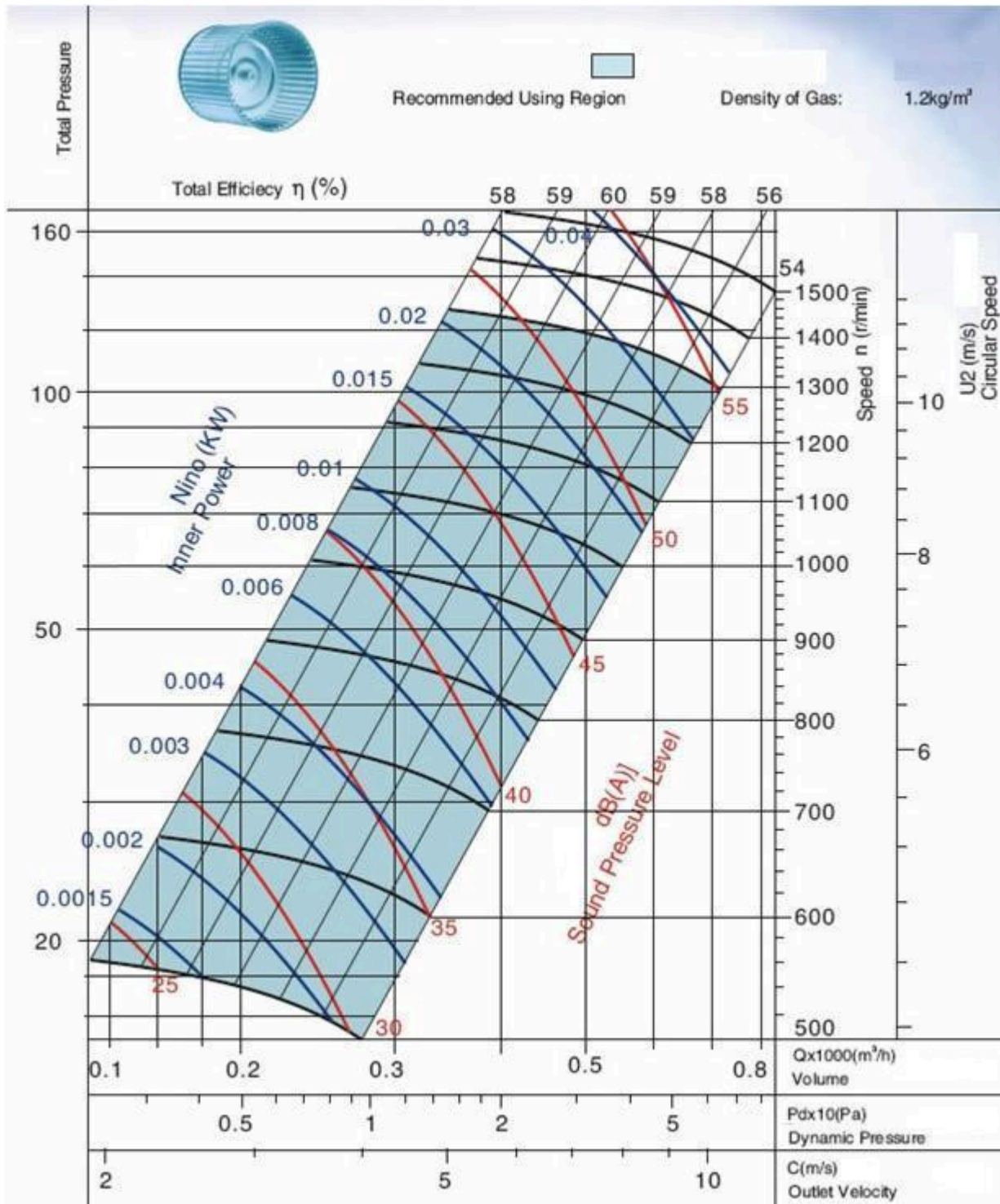

## 9. Electric Characteristics

Model	Indoor Units			
	Hz	Voltage	Min.	Max.
CCACT24	60	208-230V	187V	244V
CCACT36	60	208-230V	187V	244V
CCACT48	60	208-230V	187V	244V
CCACT60	60	208-230V	187V	244V

**Remark:**

MCA: Min. Current Amps. (A)





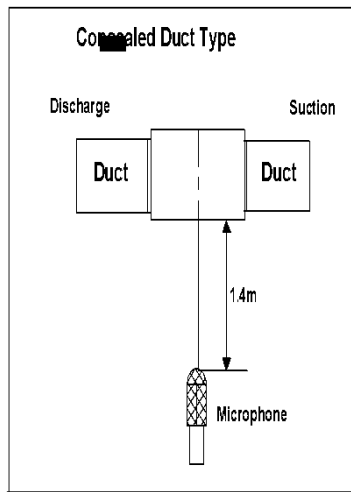

MFA: Max. Fuse Amps. (A)

## 10. Sound Levels



Model	Noise level dB(A)		
	H	M	L
CCACT24	52	45	40
CCACT36	50	47	45
CCACT48	56	54	51
CCACT60	56	54	51

## 11. Accessories

	Name	Shape	Quantity
Tubing & Fittings	Soundproof/insulation sheath		2
	Binding tape		1
	Seal sponge		1
Drainpipe Fittings	Seal ring		1
Controller	Wire controller		1
	Remote controller		0
others	Operation & installation instruction manual		1

## 12. The Specification of Power

MODEL (Cooling only)		CCACT24	CCACT36	CCACT48	CCACT60
Power	Phase	1-phase	1-phase	1-phase	1-phase
	Frequency and Voltage	208-230V, 60Hz	208-230V, 60Hz	208-230V, 60Hz	208-230V, 60Hz
Indoor Unit Power Wiring (mm <sup>2</sup> )		3x1.0	3x1.0	3x1.0	3x1.0
Indoor/Outdoor Connecting Wiring (mm <sup>2</sup> )	Ground Wiring	0.75	0.75	0.75	0.75
	Outdoor Unit Power Wiring	3x2.5	3x4.0	3x6.0	3x6.0
	Strong Electric Signal	—————	—————	—————	—————
	Weak Electric Signal	3x0.75	3x0.75	4x0.75	4x0.75

### 13. Field Wiring

CCACT24 CCACT36

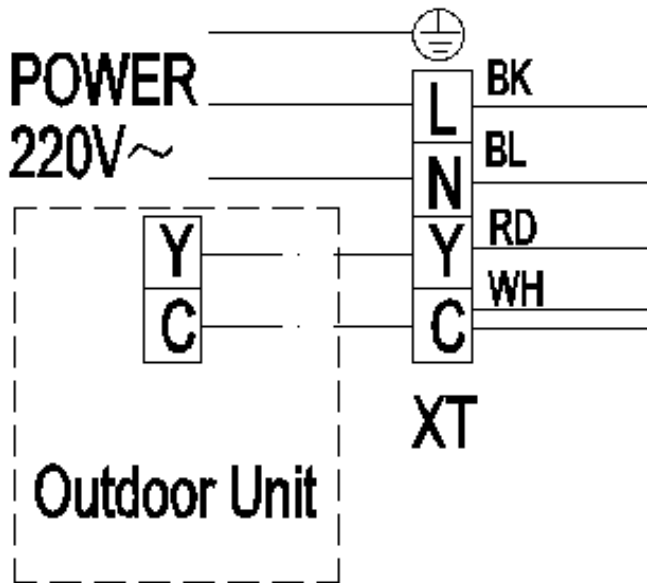

CTB-48C CTB-60C

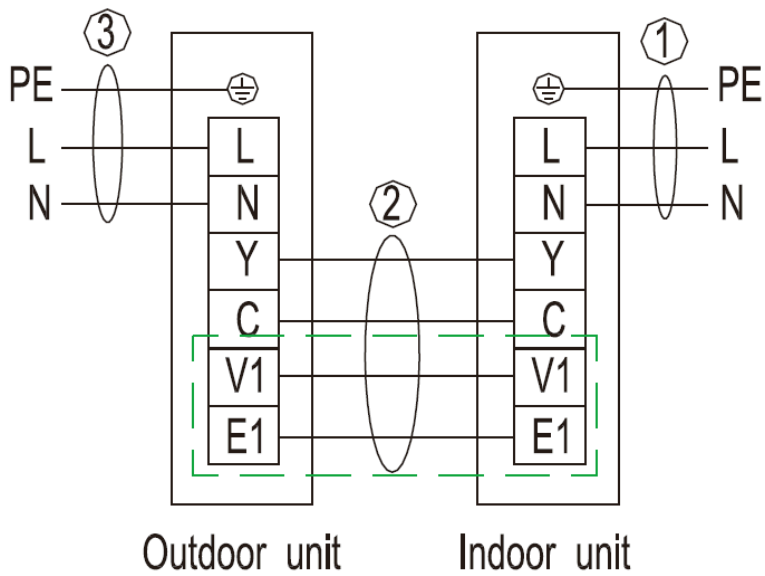





## 14.Exploded view

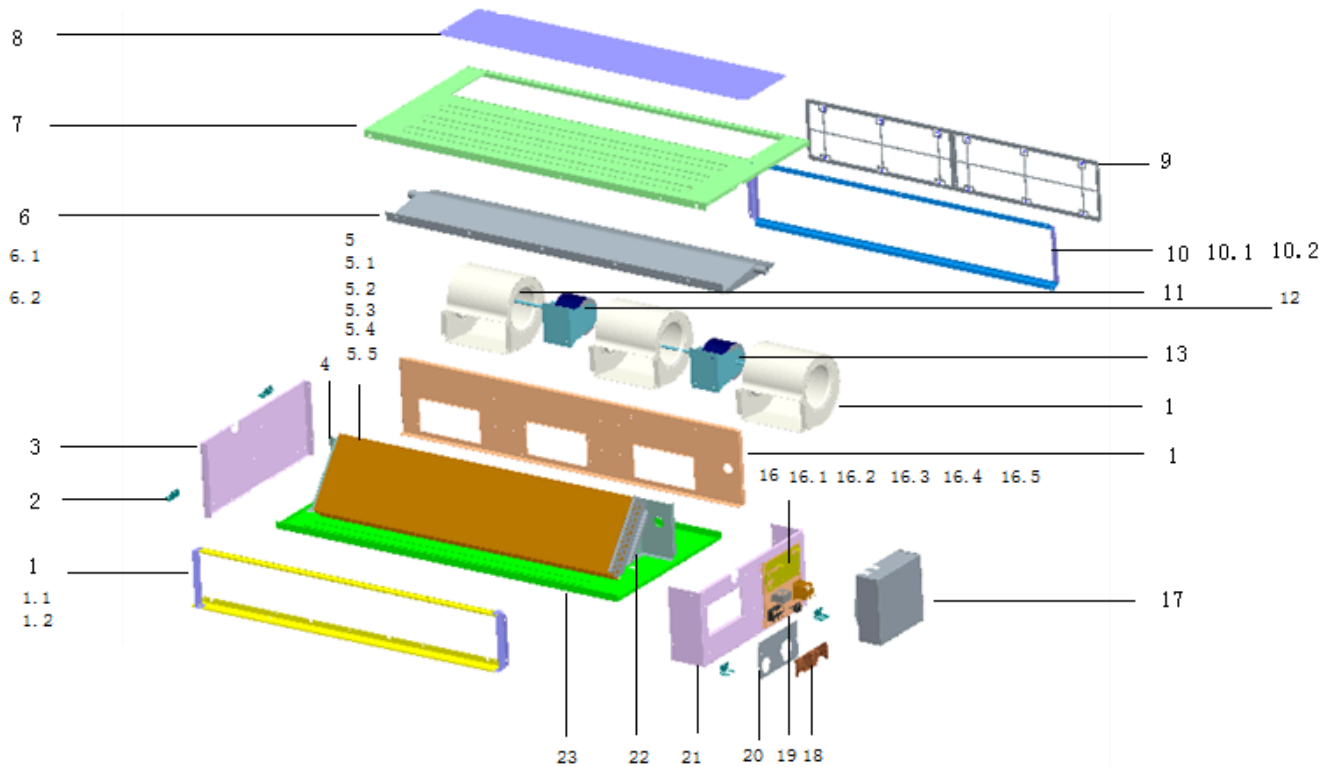

No.	Part Name	Quantity	No.	Part Name	Quantity
1	outlet assy	1	10.2	return air left-right rail	2
1.1	outlet left-right rail	2	11	scroll case(left)	1
1.2	outlet upper-lower rail	2	12	Fan motor	1
2	hanger	4	13	Fan motor	1
3	left clapboard	1	14	scroll case(right)	2
4	Left end plate of Evaporator	1	15	Fan fixing board assy	1
5	Evaporator assy	1	16	E-parts	1
5.1	Transition tube	5	16.1	Main control board	1
5.2	Shunt assy	1	16.2	Temperature sensor	1
5.3	air header assy	1	16.3	PTC transformer	1
5.4	Evaporator	1	16.4	Terminal	1
5.5	Probe copper tube	1	16.5	NO.7Line pressing buckle	2
6	Welding assy for water collector	1	17	E-parts box cover assy	1
6.1	leading	2	18	Small cover plate	1
6.2	effluent joint rubber cap	2	19	E-parts box base	1
7	Lower plate	1	20	big cover plate	1
8	Return air damper	1	21	Right clapboard	1
9	filter screen	2	22	Right end plate of Evaporator	1
10	Return air assy	1	23	Upper plate	1
10.1	return air upper-lower rail	2			

## 15. Troubleshooting

Fault code table

<b>4LED Faults</b>	<b>Digital display</b>	<b>Failure description</b>
Timer light flashing	E2	Ambient temperature sensor (T1) failure
Running light flashing	E3	Evaporator pipe temperature sensor (T2) failure
Defrost light flashing	E5	Condenser pipe temperature sensor (T3) failure
Warning light flashing	F5	Water fullfilled protection
Running light, defrost light flashing	E1	Indoor unit and wire controller communication failure
Running light, timer light flashing	P6	Indoor unit EEPROM failure
Defrost light, timer light flashing	F0	Indoor fan stall protection
Defrost light, warning light flashing	F2	Outdoor protection
	F7	outdoor unit over-current protection
Timer light, warning light flashing	E0	Indoor unit and outdoor unit communication failure
Running light, defrost light, timer light flashing	F3	High pressure protection
Defrost light , timer light, warning light flashing	F4	Low pressure protection
Running light, timer light, warning light flashing	F8	Outdoor unit exhaust temperature over-high protection
Running light, defrost light, timer light, warning light flashing	F9	Three-phase electricity phase sequence failure
Note: the flashing frequency for all above indication lights is 1HZ.		

**E2: Indoor ambient temp. sensor fault (T1 sensor)**

Solution:

- (1) Check the T1 sensor connection loosen or not, inset it firmly, if not solve, go to next step;
- (2) Take out the sensor, measure the resistance of the sensor, it is about  $5K\Omega$  at  $25^{\circ}C$ , if not, replace it; if resistance normally, change the indoor main board.

**E3: Indoor evaporator pipe temperature sensor (T2) failure**

Solution:

- (1) Check the T2 sensor connection loosen or not, inset it firmly, if not solve, go to next step;
- (2) Take out the sensor, measure the resistance of the sensor, it is about  $5K\Omega$  at  $25^{\circ}C$ , if not, replace it; if resistance normally, change the indoor main board

**E5: Condenser pipe temperature sensor (T3) failure**

Solution:

- (1) Check the T3 sensor connection loosen or not, inset it firmly, if not solve, go to next step;
- (2) Take out the sensor, measure the resistance of the sensor, it is about  $5K\Omega$  at  $25^{\circ}C$ , if not, replace it; if resistance normally, change the main board

**F2: Outdoor unit protection**

Solution:

Follow the F3/F4/F8/F9.

**F3: High pressure protection**

Solution:

- (1) If the unit does not have high pressure switch, change the outdoor main board; if it has, go to next step
- (2) Take out the high-pressure switch, measure its resistance, it is about  $0\Omega$ , if not, replace it; otherwise go to next step;
- (3) Short connect the high-pressure switch port on the outdoor board, if it still shows P1, replace the outdoor main board; otherwise go to next step;
- (4) Connect the pressure gauge to test the high pressure, if it is real too high, may be cause by too much refrigerant or other gas getting inside the system

**F4: Low pressure protection**

Solution:

- (1) If the unit does not have low pressure switch, change the outdoor main board; if it has, go to next step
- (2) Take out the low-pressure switch, measure its resistance, confirm whether it is about  $0\Omega$ , if not, replace it; otherwise go to next step;
- (3) Short connect the low-pressure switch port on the outdoor board, if it still shows P2, replace the outdoor main board; otherwise go to next step;
- (4) Connect the pressure gauge to test the low pressure, if it is real too low, may be cause by lack of refrigerant or leakage in the refrigerant system

**F5: Water fulfilled protection (Alarm of condensing water overflow)**

Solution:

- (1) If the unit does not have water drainage pump:
  - a) Check the water level switch short connect or not, if not, short connect it, if it still not solves, change the main board
- (2) If the unit has water drainage pump:
  - b) Check the water level switch if it is connected well, inset it firmly; then check the switch is blocked or not, if it is blocked, replace it, otherwise go to next step
  - b) Check the connection between pump and main board if it is 220-240V, if it is, change the water pump; if not, change the indoor main board

**F7: Outdoor overcurrent protection**

Solution:

- (1) Check the dial-switches is setting corrected or not according to the wiring diagram, if not, set it corrected; if corrected, go to next step
- (2) Check the condenser whether it is in good ventilation, if not, remove the blockage; otherwise go to the

next step.

(3) Measure the current with multimeter, and check the current via the unit check data also, compare these two data, if they are quite different, change the outdoor main board;

(4) If all above steps done normally, it may be caused damaged compressor or refrigerant system blocked or dirty or other gas get inside the system

**F8: Outdoor unit exhaust temperature over-high protection**

Solution:

(1) Check the T5 sensor connection loosen or not, inset it firmly, if not solve, go to next step;

(2) Take out the exhaust sensor (T5) from main board, measure its resistance, it is about 50K $\Omega$  at 25 $^{\circ}$ C, if not, change the sensor; if it is, go to next step

(3) Remove the sensor from the compressor, if it still not solves, change the main board

(4) If all above steps done normally, it may be caused lack of refrigerant or damaged compressor or refrigerant system blocked or dirty or other gas get inside the system.

**F9: Three-phase electricity power phase sequence failure**

Solution:

(1) Check the 3-phase power connection lines are connected well or not

(2) Using the meter to measure the voltage (L1&N, L2&N, L3&N), all of them should be 220V, if not, correct the power supply, otherwise go to next step;

(3) If the power supply is corrected, change the main board

**P6: EEPROM failure**

Change the indoor mainboard

## 3.Ceiling & Floor Type

<b>1. Features</b>	<b>45</b>
<b>2. Specifications</b>	<b>46</b>
<b>3. Dimensions</b>	<b>47</b>
<b>4. Service Space</b>	<b>48</b>
<b>5. Wiring Diagrams</b>	<b>49</b>
<b>6. Capacity Tables</b>	<b>51</b>
<b>7. Electric Characteristics</b>	<b>53</b>
<b>8. Sound Levels</b>	<b>54</b>
<b>9. Accessories</b>	<b>57</b>
<b>10. The Specification of Power</b>	<b>58</b>
<b>11. Field Wiring</b>	<b>59</b>
<b>12. Exploded View</b>	<b>60</b>
<b>13. TroubleShooting</b>	<b>66</b>

## 1. Features

1. Flexible installation, ceiling suspended and floor standing.

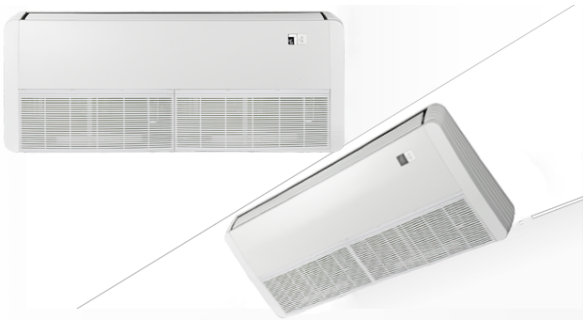

2. Washable air filter.

3. Auto-swing function, built-in two louver motor, vertical and horizontal air-flow adjustment.



4. Built-in with water pump, pumping head is up to 1200mm (Option).

5. Adopting waterproof plastic film on water collector, avoiding water leakage



6. Self-diagnostic function and multi protection.



7. Auto-restart function.



## 2. Specifications

Model (Floor Ceiling Indoor Unit)			CUAi-24CNR1	CUAi-36CNR1	CUAi-60CNR1
Code			821023700025	821024300048	821025500038
Power supply		V-Ph-H z	220V-1Ph-60Hz	220V-1Ph-60Hz	220V-1Ph-60Hz
Cooling	Capacity	Btu/h	24000	36000	60000
	Capacity	W	7032	10548	17580
	Input	W	2912	4013	7200
	Rated current	A	11.12	17.5	34.85
	Input(indoor unit)	W	420	240	420
	Rated current(indoor unit)	A	0.72	0.72	1.45
	EER	Btu/h.W	9.88	9.38	8.70
	EER	W/W	2.41	2.63	2.44
Operation Control		\	wired	wired	wired
Indoor coil	Number of rows		3	3	3
	Tube pitch(a)x row pitch(b)	mm	21×13.37	21×13.37	21×13.37
	Fin spacing	mm	1.4	1.4	1.4
	Fin type		Hydrophilic	Hydrophilic	Hydrophilic
	Tube outside dia. and type	mm	7	7	7
			inner grooved	inner grooved	inner grooved
	Coil length x height x width	mm	680×252×40.11	948×252×40.11	1318×252×70
Number of circuits		4	4	5	
Indoor air flow(High speed)		m <sup>3</sup> /h	1200	2400	2100
Indoor noise level		dB(A)	48-52	51-57	55
Indoor unit	Dimension(W*H*D)	mm	1050×235×675	1250×235×675	1670×235×675
	Packing(W*H*D)	mm	1130×325×765	1380×325×765	1750×325×770
	Net/Gross weight	Kg	26.5/31	40/50	40/46
Indoor fan motor	Brand		Kaibang	Weiling	Kaibang
	Model		YSK110-59LD-4P17	YSK110-180LD-4P2	YSK110-59LD-4P17
	Input	W	135	360	135*2
	Output	W	70	180	70*2
	Capacitor	uF	3	5	3*2
	Speed(hi/mi/lo)	r/min	1310/1139/1060	1330/1230/1130	1310/1139/1016
Refrigerant piping	Liquid side/ Gas side	mm	Φ9.52/Φ15.88	Φ9.52/Φ19.05	Φ9.52/Φ19.05
	Max. Pipe length	m	20	20	20
	Max. Fall	m	10	10	10
Connection wiring	Power wiring	mm <sup>2</sup>	3×1.0	3×1.0	3×1.0
	Signal wiring	mm <sup>2</sup>	2×0.75	2×0.75	4×0.75
Operation temp		°C	16-32	16-32	16-32
Draining pipe dimension		mm	Φ25	Φ25	Φ25

### 3. Dimensions

CUAi-24CR1 CUAi-36CR1 CUAi-48CR1 CUAi-60CR1

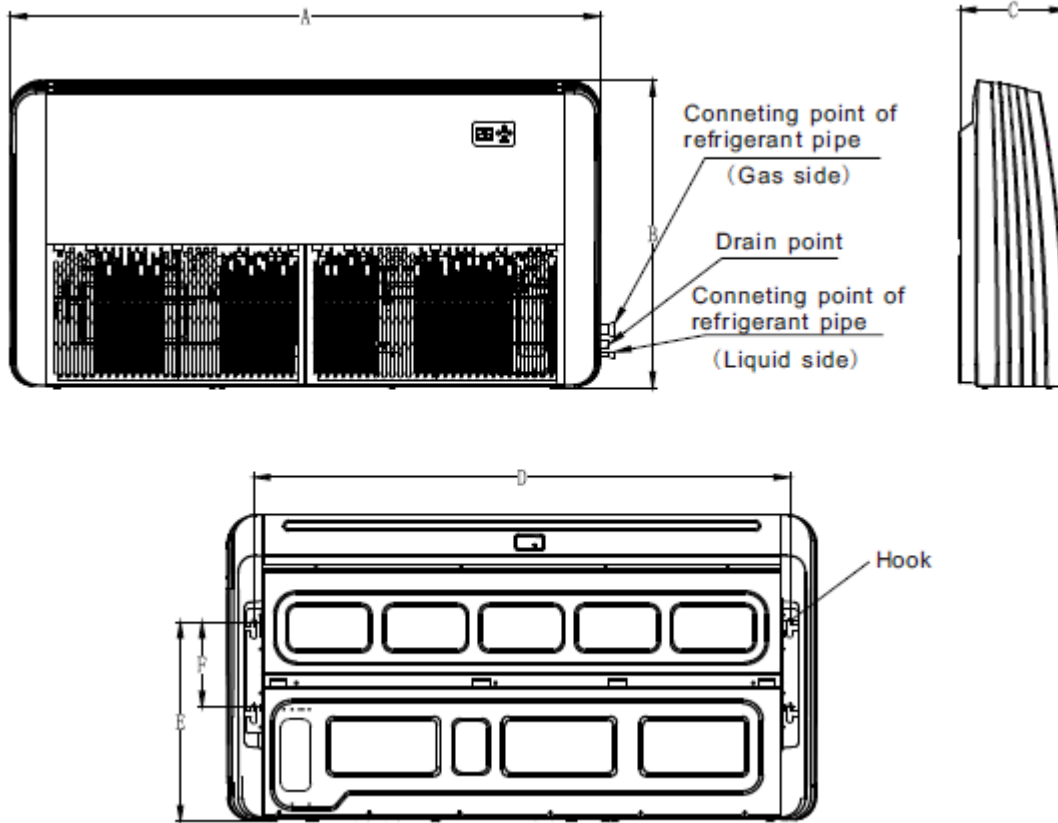

Model (kBtu/h)	A(mm)	B(mm)	C(mm)	D(mm)	E(mm)	F(mm)
24	1050	675	235	933	440	188
36	1300	675	235	1185	440	188
48-60	1670	675	235	1553	440	188



## 4. Service Space

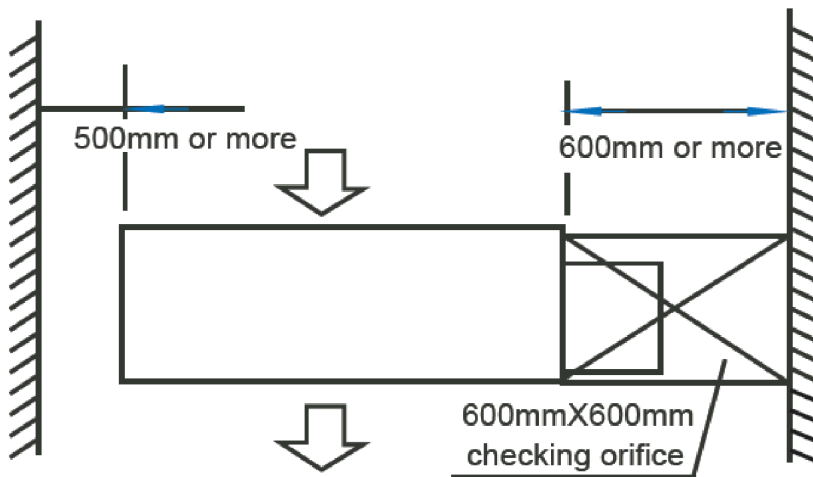
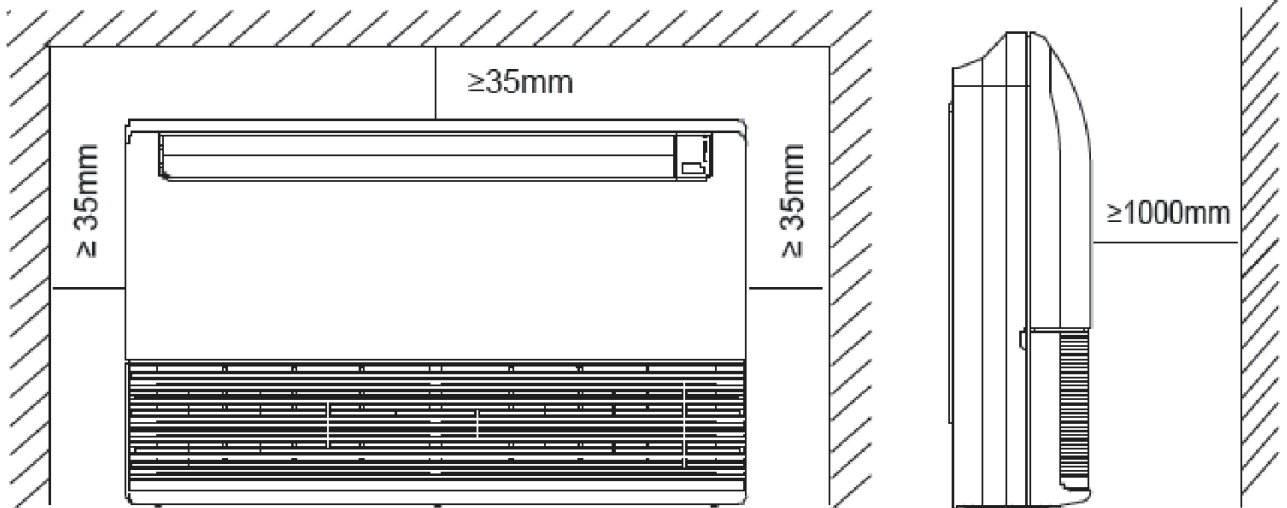

There is enough space for installation and maintenance. The ceiling is horizontal, and its structure can endure the weight of the indoor unit. The outlet and the inlet are not impeded, and the influence of external air is the least. The air flow can reach throughout the room. The connecting pipe and drainpipe could be extracted out easily. There is no direct radiation from heater.

## 5. Wiring Diagrams

CUAi-24CR1 CUAi-36CR1

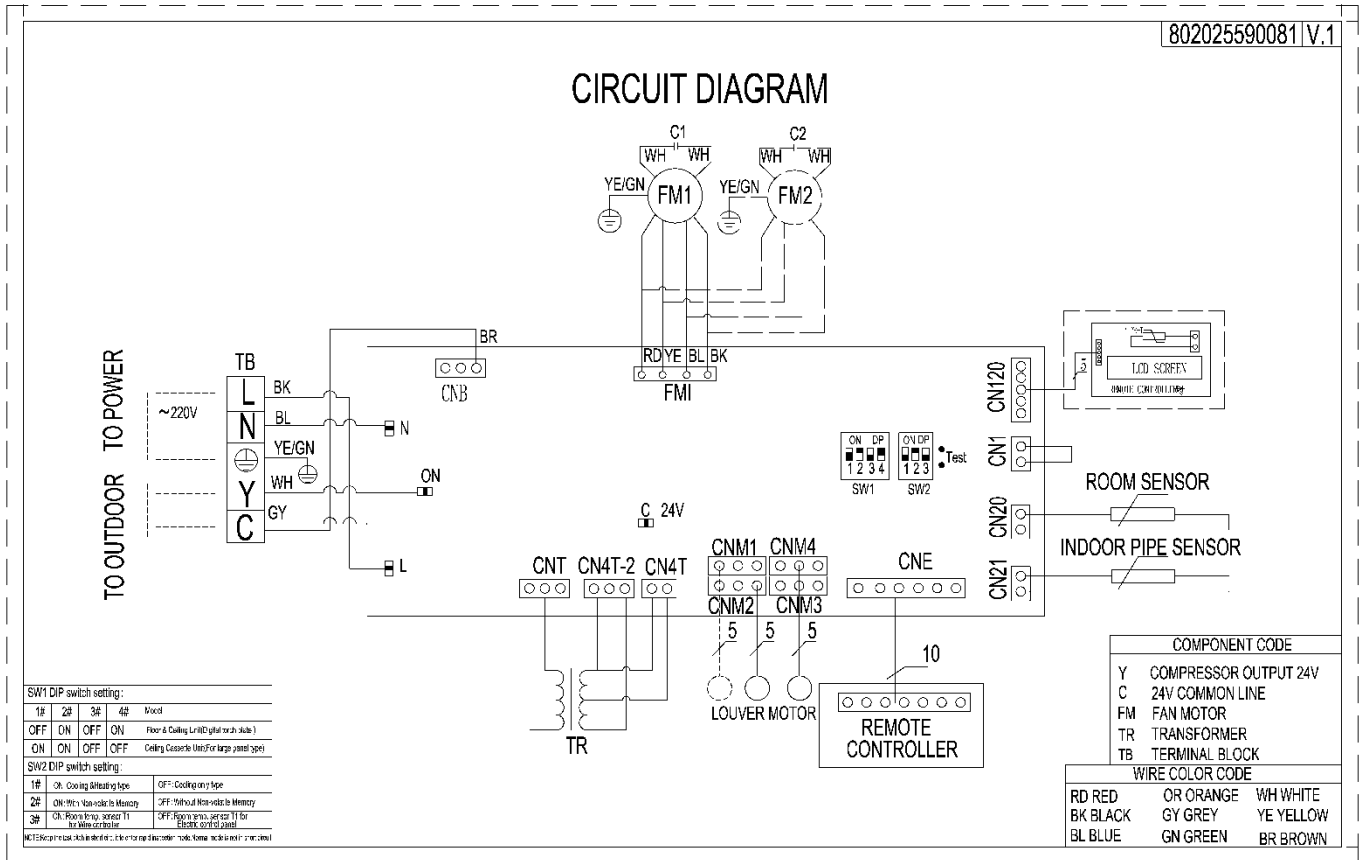

SW1 DIP switch setting:				
1#	2#	3#	4#	Model
OFF	ON	OFF	ON	Floor & Ceiling Unit(Digital torch plate )
ON	ON	OFF	OFF	Ceiling Cassette Unit(For large panel type)

SW2 DIP switch setting:		
1#	2#	3#
ON	ON: Cooling & Heating type	OFF: Cooling only type
2#	ON: With Non-volatile Memory	OFF: Without Non-volatile Memory
3#	ON: Room temp. sensor T1 for Wire controller	OFF: Room temp. sensor T1 for Electric control panel

NOTE: Keep the test pitch in short circuit to enter rapid inspection mode. Normal mode is not in short circuit

CUAi-48CR1 CUAi-60CR1

802019900057 | V.0

CIRCUIT DIAGRAM

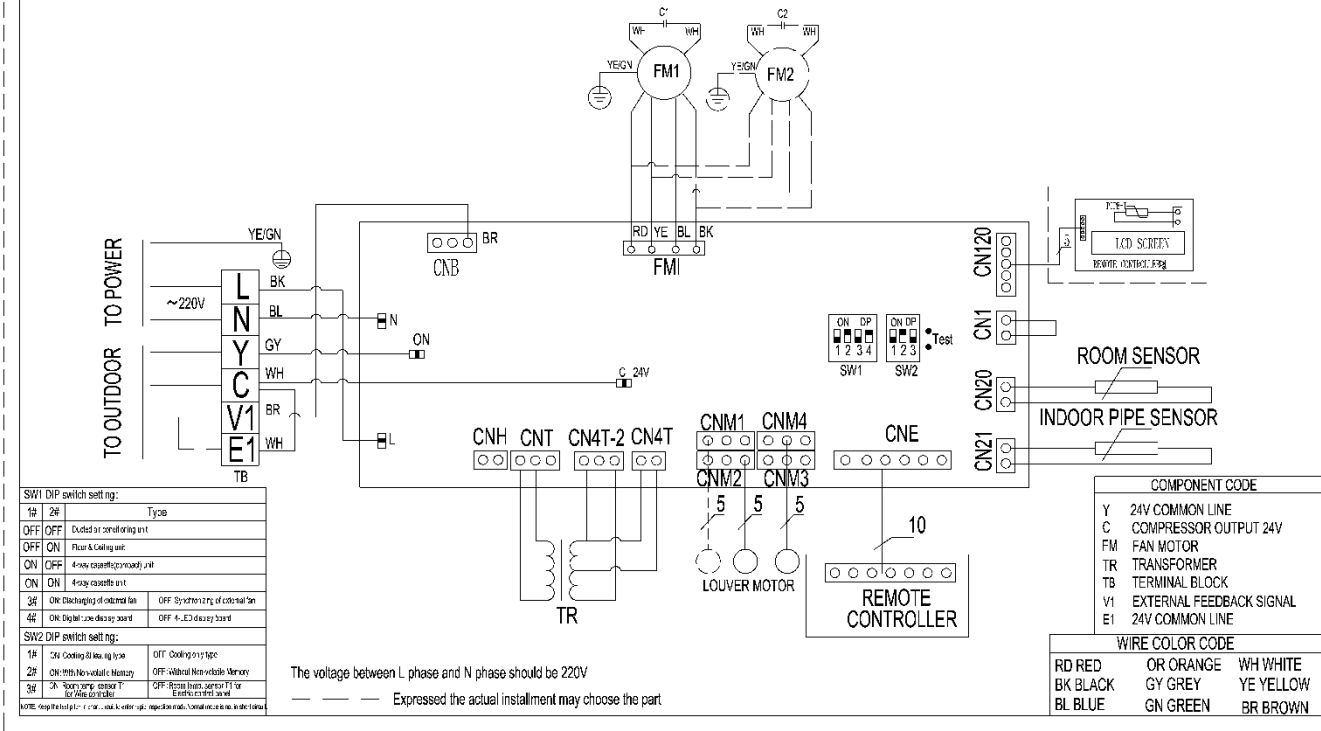

SW1 DIP switch setting:

1#	2#	Type
OFF	OFF	Excluded air conditioning unit
OFF	ON	Phase & Cooling unit
ON	OFF	4-way capacitor (compressor) unit
ON	ON	4-way capacitor unit
3#	ON	Discharging of outdoor fan
4#	ON	Digital load display board
	OFF	Synchronization of outdoor fan
	OFF	4-EX display board

SW2 DIP switch setting:

1#	2#	3#	OFF	Cooling only type
ON	ON	ON	OFF	Combined Non-vehicle Memory
ON	ON	ON	OFF	Remote from approval for External control board

NOTE: The dip switch is located on the back of the outdoor unit. The location of the dip switch is shown in the diagram.

COMPONENT CODE

Y	24V COMMON LINE
C	COMPRESSOR OUTPUT 24V
FM	FAN MOTOR
TR	TRANSFORMER
TB	TERMINAL BLOCK
V1	EXTERNAL FEEDBACK SIGNAL
E1	24V COMMON LINE

WIRE COLOR CODE

RD	RED	OR	ORANGE	WH	WHITE
BK	BLACK	GY	GREY	YE	YELLOW
BL	BLUE	GN	GREEN	BR	BROWN

The voltage between L phase and N phase should be 220V  
 --- Expressed the actual installation may choose the part

SW1 DIP switch setting:		
1#	2#	Type
OFF	OFF	Ducted air conditioning unit
OFF	ON	Floor & Ceiling unit
ON	OFF	4-way cassette(compact) unit
ON	ON	4-way cassette unit
3#	ON: Discharging of external fan	OFF: Synchronizing of external fan
4#	ON: Digital tube display board	OFF: 4-LED display board
SW2 DIP switch setting:		
1#	ON: Cooling & Heating type	OFF: Cooling only type
2#	ON: With Non-volatile Memory	OFF: Without Non-volatile Memory
3#	ON: Room temp. sensor T1 for Wire controller	OFF: Room temp. sensor T1 for Electric control panel
NOTE: Keep the test pitch in short circuit to enter rapid inspection mode. Normal mode is not in short circuit.		

## 6. Capacity Tables

### 6.1 Cooling Capacity

#### CUAi-24CR1

Cooling		Outdoor conditions (DB)			
Indoor Conditions	(kW)	21°C	28°C	35°C	43°C
21/15°C DB/WB	TC	7.31	6.96	6.60	6.32
	SC	5.41	5.36	5.28	5.31
	Input	2.08	2.26	2.36	2.43
24/17°C DB/WB	TC	7.53	7.17	6.82	6.39
	SC	5.64	5.59	5.52	5.37
	Input	2.21	2.36	2.46	2.59
27/19°C DB/WB	TC	7.67	7.31	<b>7.10</b>	6.60
	SC	5.67	5.63	5.54	5.41
	Input	2.26	2.38	<b>2.51</b>	2.64
32/23°C DB/WB	TC	7.81	7.53	7.38	6.82
	SC	6.64	6.55	6.50	6.34
	Input	2.36	2.46	2.64	2.74

#### CUAi-36CR1

Cooling		Outdoor conditions (DB)			
Indoor Conditions	(kW)	21°C	28°C	35°C	43°C
21/15°C DB/WB	TC	10.82	10.29	9.77	9.35
	SC	8.00	7.92	7.81	7.85
	Input	3.15	3.42	3.57	3.69
24/17°C DB/WB	TC	11.13	10.61	10.08	9.45
	SC	8.35	8.27	8.16	7.94
	Input	3.34	3.57	3.72	3.91
27/19°C DB/WB	TC	11.34	10.82	<b>10.50</b>	9.77
	SC	8.39	8.33	8.19	8.01
	Input	3.42	3.61	<b>3.80</b>	3.99
32/23°C DB/WB	TC	11.55	11.13	10.92	10.08
	SC	9.82	9.68	9.61	9.37
	Input	3.57	3.72	3.99	4.14

#### CUAi-48CR1

Cooling		Outdoor conditions (DB)			
Indoor Conditions	(kW)	21°C	28°C	35°C	43°C
21/15°C DB/WB	TC	14.42	13.72	13.02	12.46
	SC	10.67	10.56	10.42	10.47
	Input	4.29	4.65	4.86	5.01
24/17°C DB/WB	TC	14.84	14.14	13.44	12.60
	SC	11.13	11.03	10.89	10.58
	Input	4.55	4.86	5.07	5.33
27/19°C DB/WB	TC	15.12	14.42	<b>14.00</b>	13.02
	SC	11.19	11.10	10.92	10.68
	Input	4.65	4.91	<b>5.17</b>	5.43
32/23°C DB/WB	TC	15.40	14.84	14.56	13.44
	SC	13.09	12.91	12.81	12.50
	Input	4.86	5.07	5.43	5.64

**CUAi-60CR1**

Cooling		Outdoor conditions (DB)			
Indoor Conditions	(kW)	21°C	28°C	35°C	43°C
21/15°C DB/WB	TC	16.48	15.68	14.88	14.24
	SC	12.20	12.07	11.90	11.96
	Input	4.98	5.40	5.64	5.82
24/17°C DB/WB	TC	16.96	16.16	15.36	14.40
	SC	12.72	12.60	12.44	12.10
	Input	5.28	5.64	5.88	6.18
27/19°C DB/WB	TC	17.28	16.48	<b>16.00</b>	14.88
	SC	12.79	12.69	12.48	12.20
	Input	5.40	5.70	<b>6.00</b>	6.30
32/23°C DB/WB	TC	17.60	16.96	16.64	15.36
	SC	14.96	14.76	14.64	14.28
	Input	5.64	5.88	6.30	6.54

**Remark:**

TC: Total capacity; kW  
 SC: Sensible heat capacity; kW  
 Input: Input power; Kw

## 7. Electric Characteristics

Model	Indoor Units			
	Hz	Voltage	Min.	Max.
CUAi-24CR1	60	208-230V	187V	244V
CUAi-36CR1	60	208-230V	187V	244V
CUAi-48CR1	60	208-230V	187V	244V
CUAi-60CR1	60	208-230V	187V	244V

## 8. Sound Levels

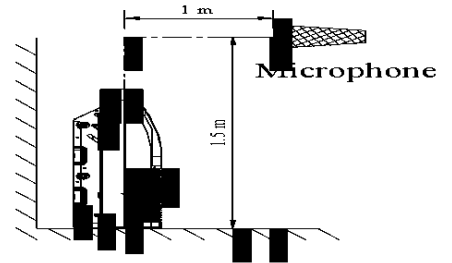
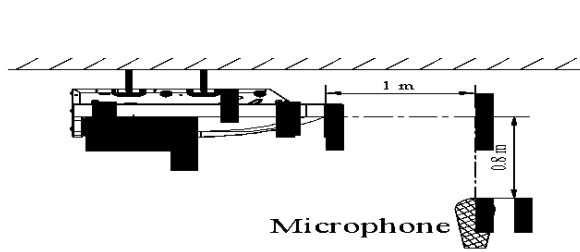

### CUAi-24CR1

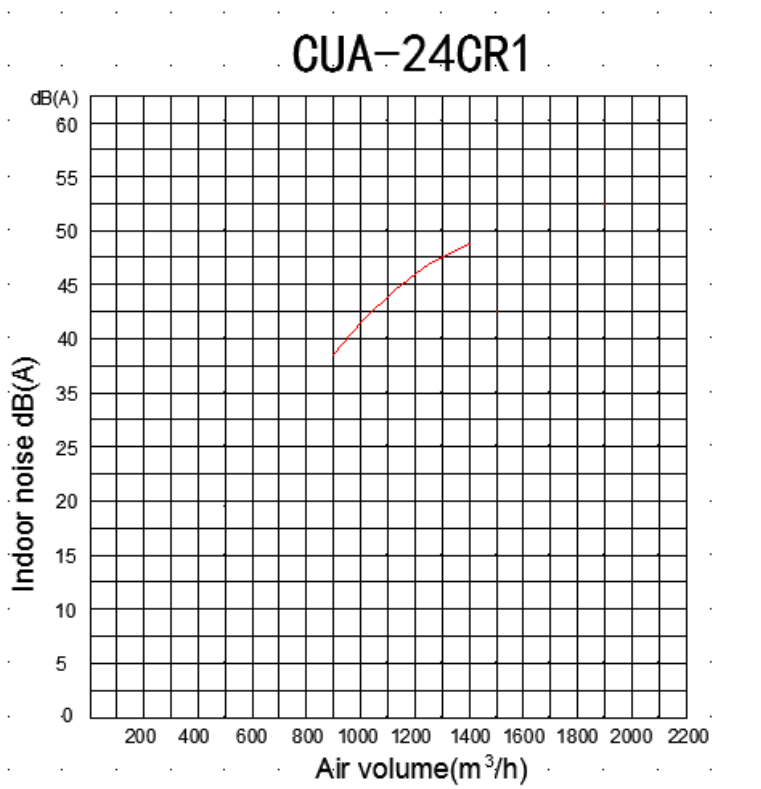



CUAi-36CR1

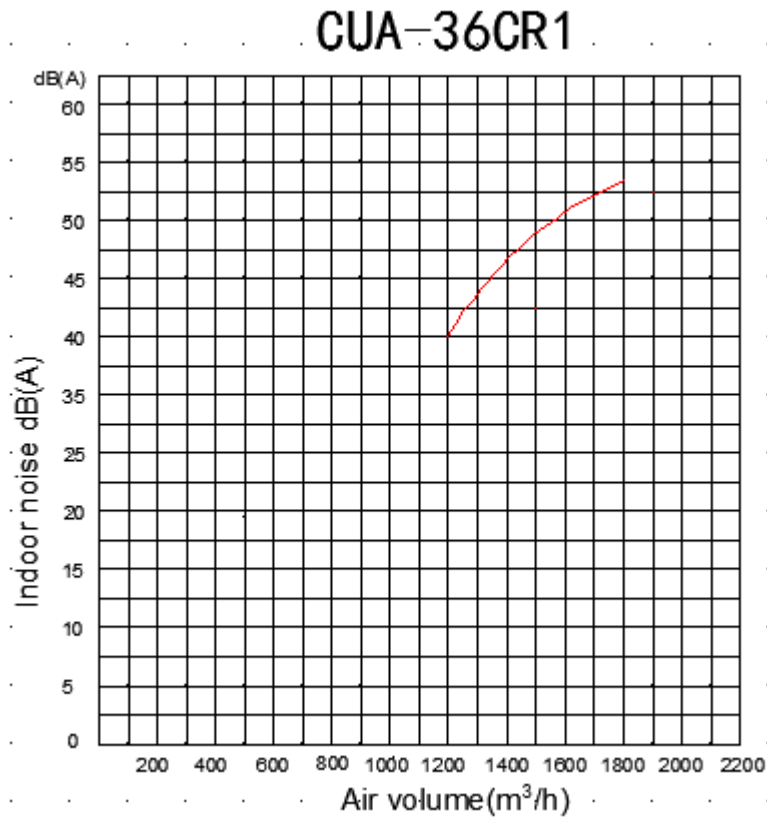

CUAi-48CR1

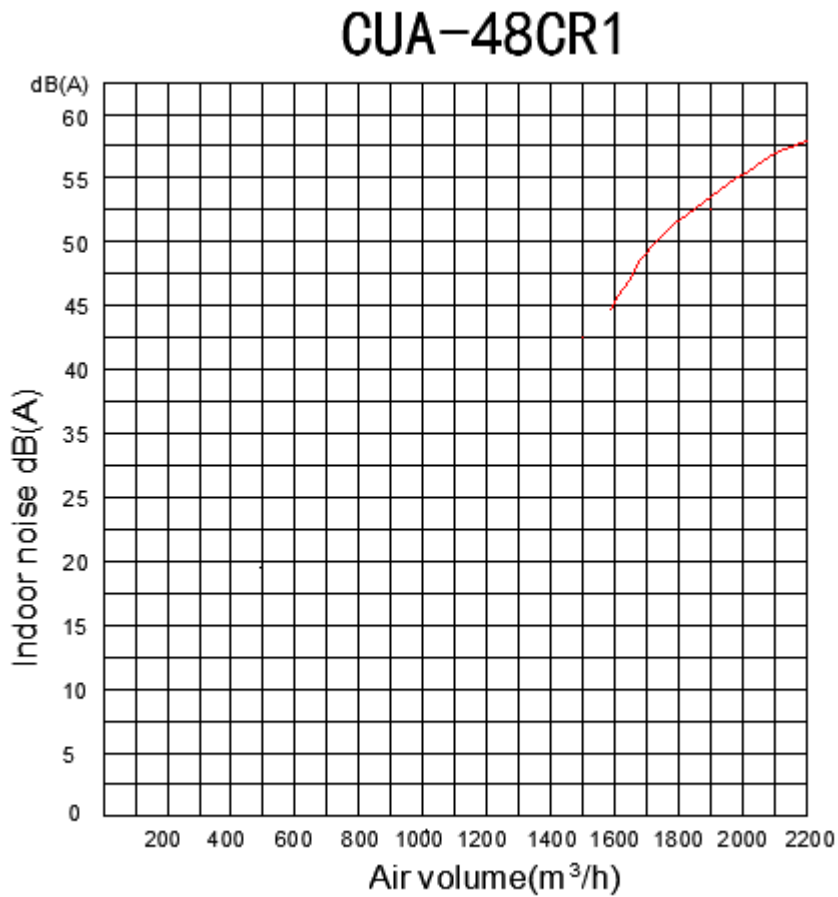





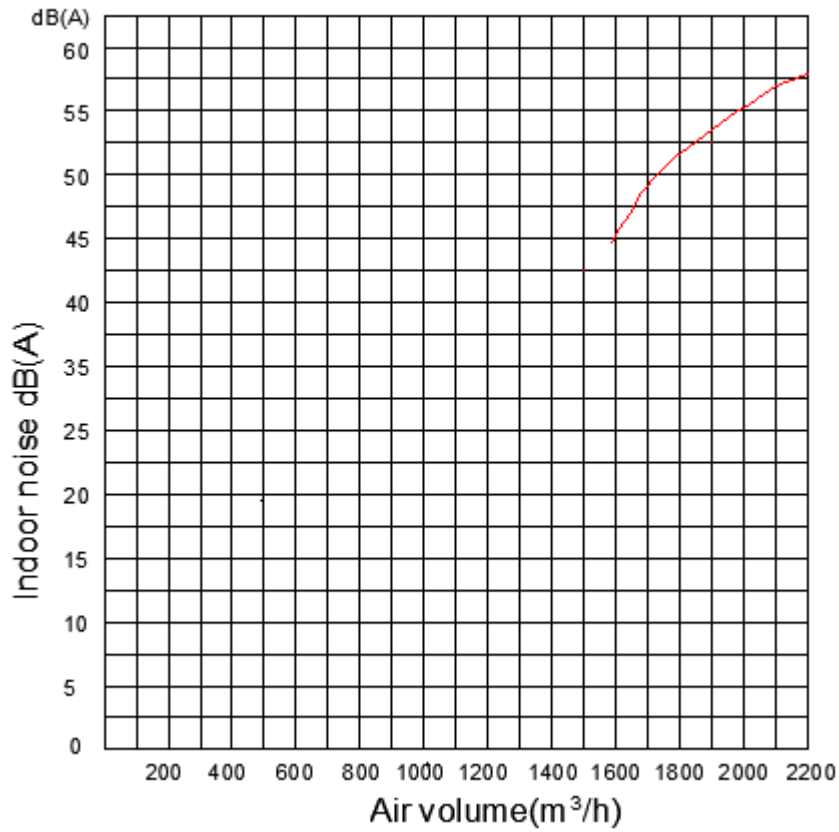

CUAi-60CR1

## CUA-60CR1



Model	Noise level dB(A)		
	H	M	L
CUAi-24CR1	53	49	46
CUAi-36CR1	56	53	51
CUAi-48CR1	56	53	51
CUAi-60CR1	57	54	51

## 9. Accessories

	Name	Shape	Quantity
Installation fittings	1.Hanging arm		2
	2. Remote controller		1
Controller	3. Remote controller holder (optional)		1
	4. Wire controller		1
	5. Mounting screw (ST2.9×10-C-H)		2
	6. Alkaline dry batteries (AM4)		2
Others	7. Installation & operation instruction manual		1

## 10.The Specification of Power

Type (cooling only)		24	36	48	60
Power	Phase	1-phase	1-phase	1-phase	1-phase
	Frequency and Voltage	208-230V, 60Hz	208-230V, 60Hz	208-230V, 60Hz	208-230V, 60Hz
Indoor Unit Power Wiring (mm <sup>2</sup> )		3×1.0	3×1.0	3×1.0	3×1.0
Indoor/Outdoor Connecting Wiring (mm <sup>2</sup> )	Ground Wiring	0.75	0.75	0.75	0.75
	Outdoor Unit Power Wiring	3×2.5	3×4.0	3×4.0	3×6.0
	Strong Electric Signal	-	-	-	-
	Weak Electric Signal	3×0.75	3×0.75	4×0.75	4×0.75

## 11. Field Wiring

CUAi-24CR1 CUAi-36CR1

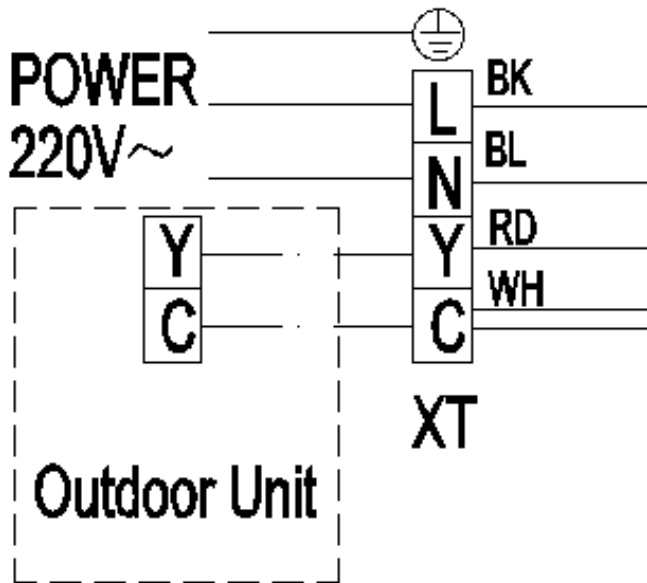

CUAi-48CR1 CUAi-60CR1

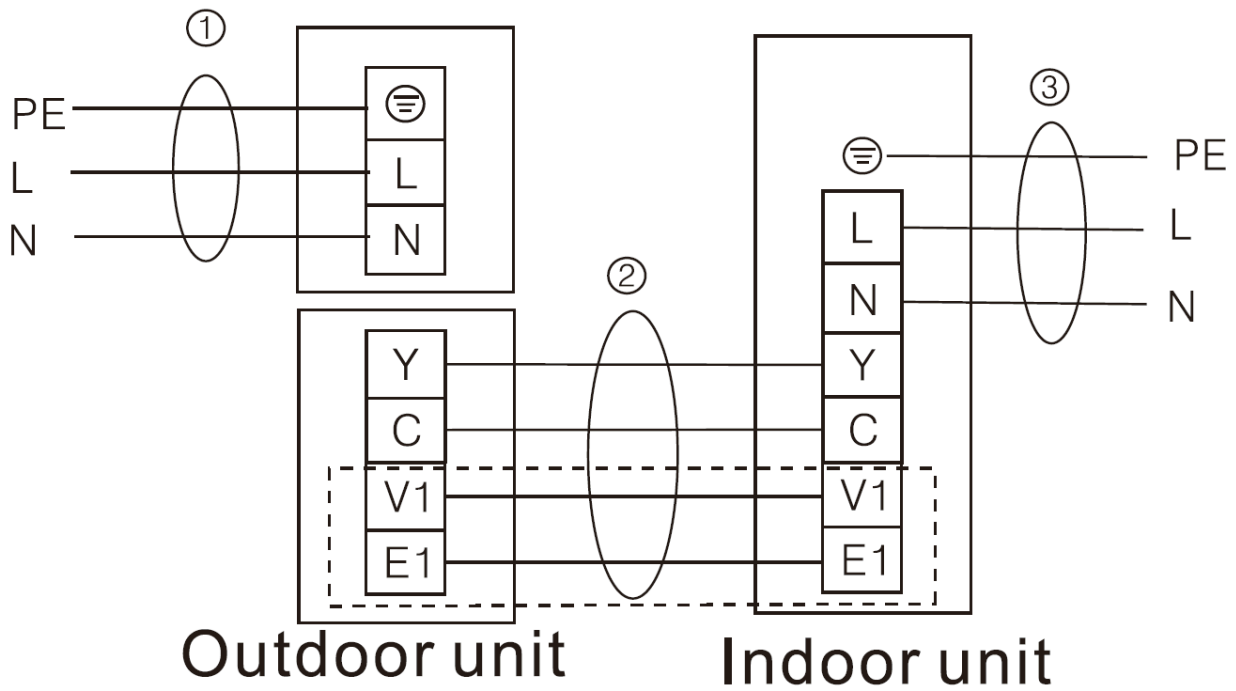

## 12. Exploded View

### (1) CUAi-24CNR1

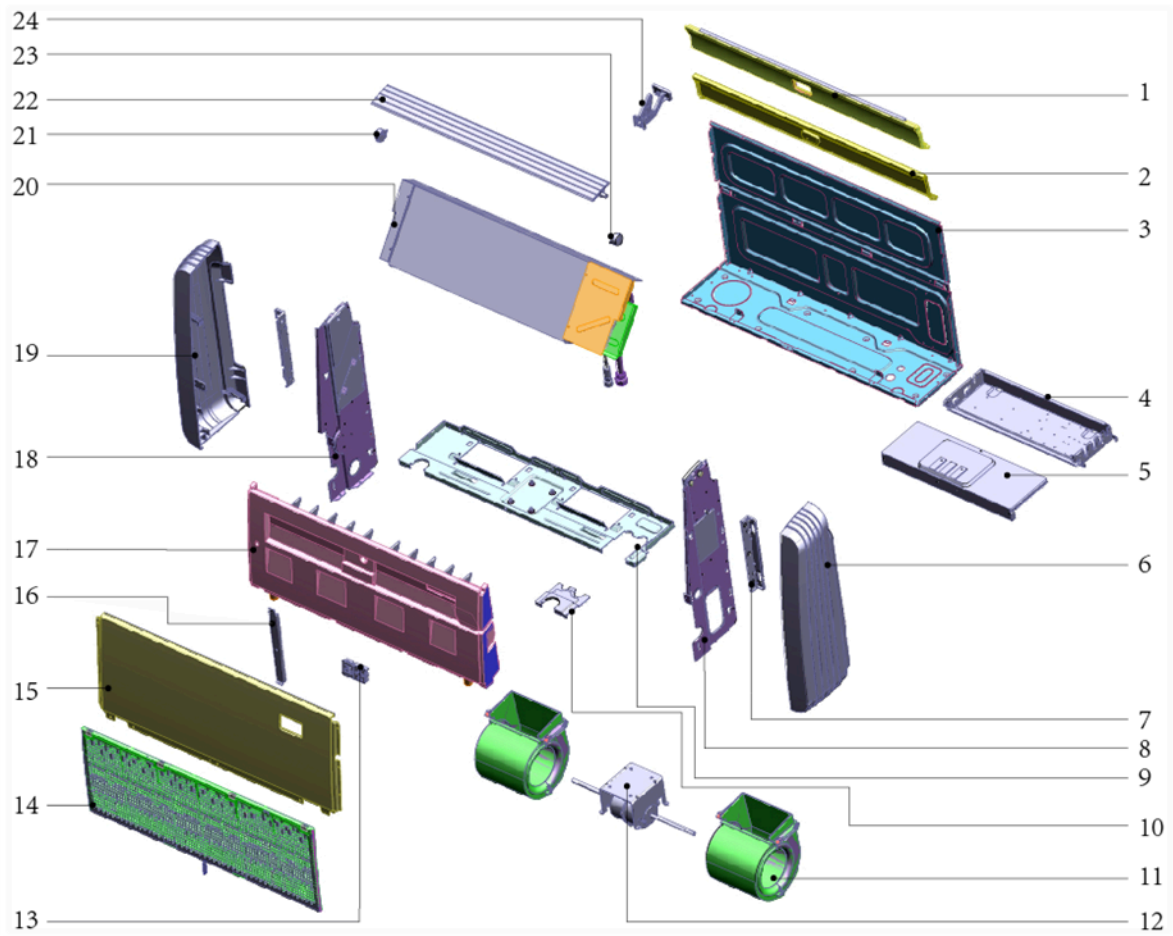

No.	Part Name	Quantity	No.	Part Name	Quantity
1	Chassis foam assembly	1	13.2	Display film	1
2	Rear cover	1	13.3	Display board mounting box	1
3	Chassis assembly	1	14	Air inlet grille	1
4	Indoor PCB assembly	1	15	Top Cover assembly	1
4.1	E-part box	1	16	Supporting board	1
4.2	Indoor PCB	1	17.1	Drip tray foam	1
4.3	Fan capacitor	1	17.2	Louver connecting rod fixed structure class1	1
4.4	Transformer	1	17.3	Louver connecting rod fixed structure class2	1
4.5	Temperature sensors (indoor )	1	17.4	Driving lever for louver	1
4.6	Terminal	1	17.5	Louver holder	1
5	E-part box cover	1	17.6	Guard vane	9
6	Left cover	1	18	Right separating board	1
7	Hoisting pate	2	19	Right cover	1
8	Lelf separating board	1	20	Evaporator component	1
9	Weld assembly for intermediate transverse girder	1	20.1	Evaporator assembly	1
10	Pipe clamp	1	20.2	Evaporator output tube assembly	1
11.1	Centrifugal fan blade	2	20.3	Evaporator input tube assembly	1
11.2	Upper volute	2	20.4	Under the right mounting plate of the evaporator	1
11.3	Lower volute	2	20.5	Under the left mounting plate of the evaporator	1
12.1	The motor bracket	1	20.6	Upper the right mounting plate of the evaporator	1
12.2	Motor shaft sleeve right gland	1	20.7	Upper the left mounting plate of the evaporator	1
12.3	Motor shaft sleeve left gland	1	21	Step motor	1
12.4	Motor separating board	1	22	Horizontal louver assembly	1
12.5	Indoor fan motor	1	23	Step motor	1
13	Display panel assembly	1	24	Air guide bracke	1
13.1	Display panel components	1			

(2) CUAi-36CNR1

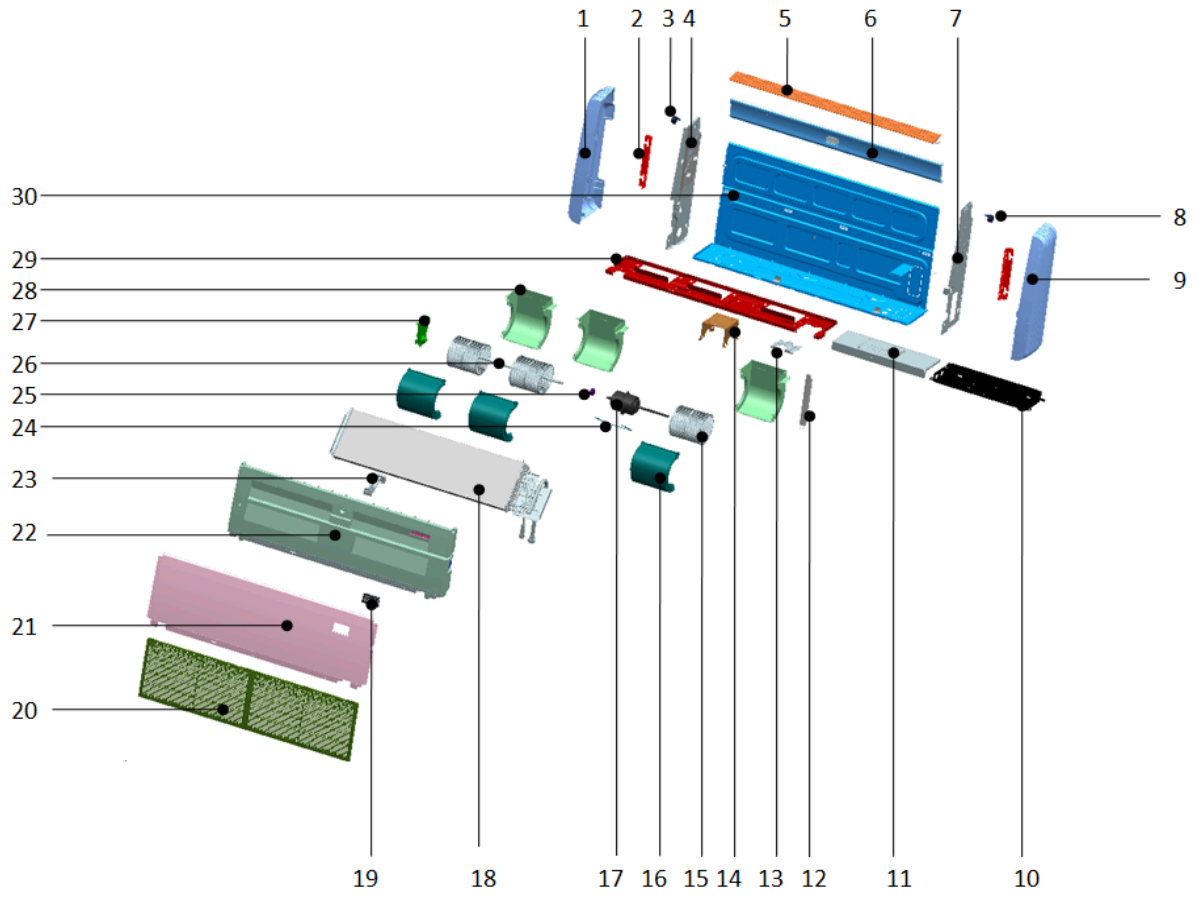



No.	Part Name	Quantity	No.	Part Name	Quantity
1	Left cover	1	18.2	Temperature Sensor	1
2	Install lifting ears	2	18.3	Under the right mounting plate of the evaporator	1
3	Stepper motor	1	18.4	Under the left mounting plate of the evaporator	1
4	Left panel assembly	1	18.5	Upper the right mounting plate of the evaporator	1
5	Air guide assembly	1	18.6	Upper the left mounting plate of the evaporator	1
6	Rear Cover	1	19	Display panel components	1
7	Right panel assembly	1	19.1	Digital Tube	1
8	Stepper motor	1	19.2	Show mask	1
9	Right cover	1	19.3	Display board mounting box	1
10	Electro Control Box assembly	1	20	Back style grille assembly	2
10.1	Electro Control Board	1	20.1	Back style grille	2
10.2	Electro Control Box	1	20.2	Dust filter	2
10.3	Temperature Sensor	1	20.3	Grille buckle	4
10.4	Terminal	1	20.4	Grille screw cover	6
10.5	Short circuit Cable	1	21	Top cover parts	1
10.6	PC board isolation column	1	22	Drip tray assembly	1
10.7	Transformer	1	22.1	Drip tray foam	1
10.8	Fan Capacitor	1	22.2	Horizontal swing leaf mounting 1	1
10.9	Light board cable group	1	22.3	Horizontal swing leaf mounting 2	1
11	Electro Control Box Cover	1	22.4	Horizontal swing leaf active rod	1
12	Support bar	1	22.5	Horizontal swing leaf connecting rod 1	1
13	Piping plate	1	22.6	Wind guide blade	10
14	Motor bracket	1	22.7	Stepper motor	1
15	Centrifugal fan blade	2	23	Air guide bracket	1
16	Upper volute	3	24	Motor hoard	1
17	Fan Motor	1	25	Coupling	1
18	Evaporator component	1	26	Connecting shaft	1
18.1	Evaporator pre-welded components	1	27	Motor support assembly	1
18.1.1	Evaporator assembly	1	28	Lower volute	3
18.1.2	Evaporator output tube assembly	1	29	Middle beam welding assembly	1
18.1.3	Evaporator input tube assembly	1	30	Base assy	1

(3) CUAi-48CNR1 / CUAi-60CNR1

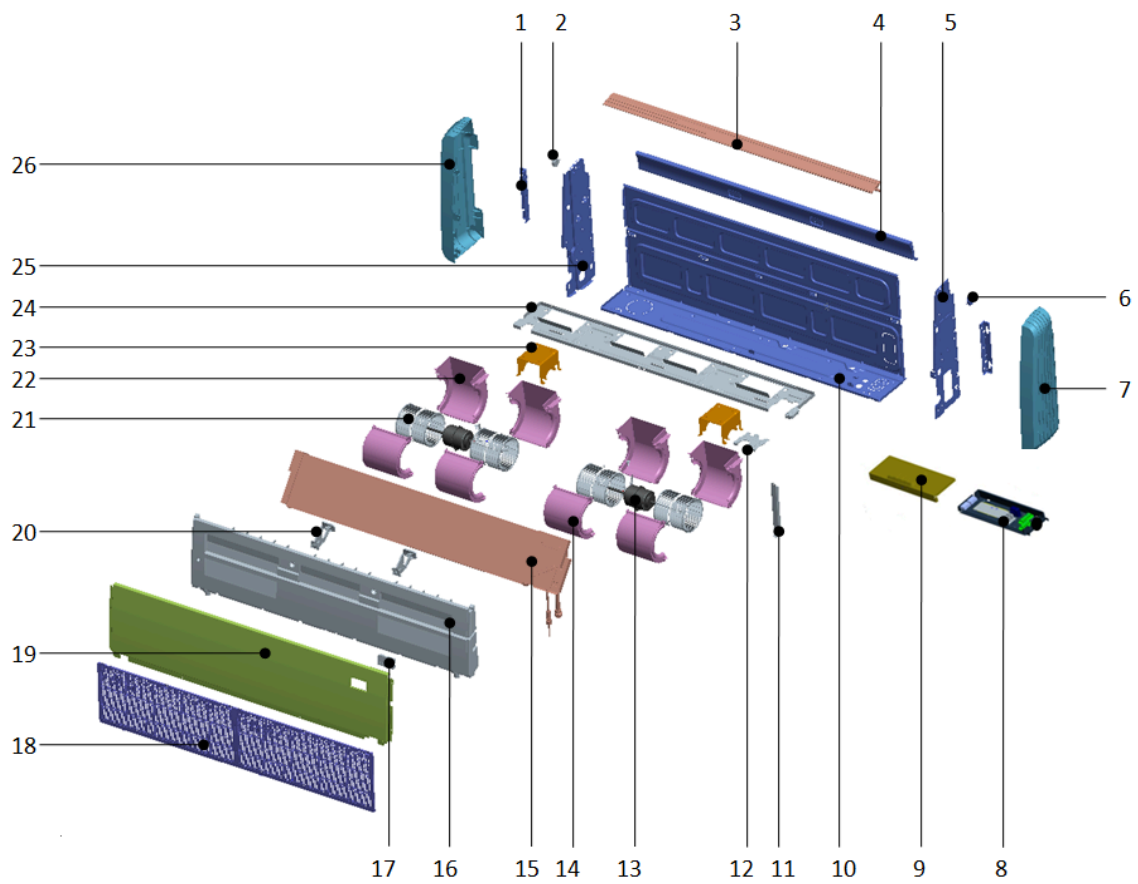

	Part Name	Quantity	No.	Part Name	Quantity
1	Right mounting plate of evaporator	1	15.7	Evaporator left lower mounting plate	1
2	Horizontal step motor	1	16	Water tray assy	1
3	Wind guide assembly	1	16.1	Water tray foam assembly	1
4	Rear cover with cotton	1	16.2	Horizontal swing leaf mount 1	1
5	Right side board assembly	1	16.3	Horizontal swing leaf mount 2	1
6	Horizontal step motor	1	16.4	Horizontal swing leaf active rod	1
7	Right cover	1	16.5	Horizontal swing leaf connecting rod 1	1
8	Indoor PCB assembly	1	16.6	Horizontal swing leaf connecting rod 2	1
8.1	E-part box	1	16.7	Wind guide blade	1
8.2	Indoor PCB	1	16.8	Vertical stepper motor	1
8.3	Terminal	1	17	Display panel assembly	1
8.4	Transformer	1	17.2	Show mask	1
8.5	Blade fan capacitor	2	17.3	Display board mounting box	1
9	Electric box cover	1	18	Back style assembly	2
10	Chassis assembly	1	18.1	Back style	2
11	Support bar	1	18.2	Filter	2
12	Pipe plate	1	18.3	Grille buckle	6
13	Indoor fan motor	2	18.4	Grille screw cover	6
14	Upper volute	4	19	Top cover assy	1
15	Evaporator assy	1	20	Wind guide bracket	2
15.1	Evaporator assembly	1	21	Centrifugal fan blade	4
15.2	Evaporator return header assembly	1	22	Lower volute	4
15.3	Evaporator splitter capillary assembly	1	23	Motor bracket	2
15.4	Evaporator right mounting plate	1	24	Middle beam welding assembly	1
15.5	Evaporator left mounting plate	1	25	Left side board assembly	1
15.6	Evaporator right lower mounting plate	1	26	Left cover	1

## 13. Troubleshooting

### Fault code

<b>4LED Faults</b>	<b>Digital display</b>	<b>Failure description</b>
Timer light flashing	E2	Ambient temperature sensor (T1) failure
Running light flashing	E3	Evaporator pipe temperature sensor (T2) failure
Defrost light flashing	E5	Condenser pipe temperature sensor (T3) failure
Warning light flashing	F5	Water fullfilled protection
Running light, defrost light flashing	E1	Indoor unit and wire controller communication failure
Running light, timer light flashing	P6	Indoor unit EEPROM failure
Defrost light, timer light flashing	F0	Indoor fan stall protection (DC Motor)
Defrost light, warning light flashing	F2	Outdoor protection (220V Communication control)
	F7	outdoor unit over-current protection (Reserve)
Timer light, warning light flashing	E0	Indoor unit and outdoor unit communication failure (RS485 Communication control)
Running light, defrost light, timer light flashing	F3	High pressure protection (RS485 Communication control)
Defrost light , timer light, warning light flashing	F4	Low pressure protection (RS485 Communication control)
Running light, timer light, warning light flashing	F8	Outdoor unit exhaust temperature over-high protection (RS485 Communication control)
Running light, defrost light, timer light, warning light flashing	F9	Three-phase electricity phase sequence failure (RS485 Communication control)
Note: the flashing frequency for all above indication lights is 1HZ.		

**E2: Indoor ambient temp. sensor fault (T1 sensor)**

Solution:

- (1) Check the T1 sensor connection loosen or not, inset it firmly, if not solve, go to next step;
- (2) Take out the sensor, measure the resistance of the sensor, it is about  $5K\Omega$  at  $25^{\circ}C$ , if not, replace it; if resistance normally, change the indoor main board.

**E3: Indoor evaporator pipe temperature sensor (T2) failure**

Solution:

- (1) Check the T2 sensor connection loosen or not, inset it firmly, if not solve, go to next step;
- (2) Take out the sensor, measure the resistance of the sensor, it is about  $5K\Omega$  at  $25^{\circ}C$ , if not, replace it; if resistance normally, change the indoor main board

**E5: Condenser pipe temperature sensor (T3) failure**

Solution:

- (1) Check the T3 sensor connection loosen or not, inset it firmly, if not solve, go to next step;
- (2) Take out the sensor, measure the resistance of the sensor, it is about  $5K\Omega$  at  $25^{\circ}C$ , if not, replace it; if resistance normally, change the main board

**F2: Outdoor unit protection**

Solution:

Follow the F3/F4/F8/F9.

**F3: High pressure protection**

Solution:

- (1) If the unit does not have high pressure switch, change the outdoor main board; if it has, go to next step
- (2) Take out the high-pressure switch, measure its resistance, it is about  $0\Omega$ , if not, replace it; otherwise go to next step;
- (3) Short connect the high-pressure switch port on the outdoor board, if it still shows P1, replace the outdoor main board; otherwise go to next step;
- (4) Connect the pressure gauge to test the high pressure, if it is real too high, may be cause by too much refrigerant or other gas getting inside the system

**F4: Low pressure protection**

Solution:

- (1) If the unit does not have low pressure switch, change the outdoor main board; if it has, go to next step
- (2) Take out the low-pressure switch, measure its resistance, confirm whether it is about  $0\Omega$ , if not, replace it; otherwise go to next step;
- (3) Short connect the low-pressure switch port on the outdoor board, if it still shows P2, replace the outdoor main board; otherwise go to next step;
- (4) Connect the pressure gauge to test the low pressure, if it is real too low, may be cause by lack of refrigerant or leakage in the refrigerant system

**F5: Water fulfilled protection (Alarm of condensing water overflow)**

Solution:

- (1) If the unit does not have water drainage pump:
  - a) Check the water level switch short connect or not, if not, short connect it, if it still not solves, change the main board
- (2) If the unit has water drainage pump:
  - c) Check the water level switch if it is connected well, inset it firmly; then check the switch is blocked or not, if it is blocked, replace it, otherwise go to next step
  - b) Check the connection between pump and main board if it is 220-240V, if it is, change the water pump; if not, change the indoor main board

**F7: Outdoor overcurrent protection**

Solution:

- (1) Check the dial-switches is setting corrected or not according to the wiring diagram, if not, set it corrected; if corrected, go to next step
- (2) Check the condenser whether it is in good ventilation, if not, remove the blockage; otherwise go to the

next step.

(3) Measure the current with multimeter, and check the current via the unit check data also, compare these two data, if they are quite different, change the outdoor main board;

(4) If all above steps done normally, it may be caused damaged compressor or refrigerant system blocked or dirty or other gas get inside the system

**F8: Outdoor unit exhaust temperature over-high protection**

Solution:

(1) Check the T5 sensor connection loosen or not, inset it firmly, if not solve, go to next step;

(2) Take out the exhaust sensor (T5) from main board, measure its resistance, it is about 50K $\Omega$  at 25 $^{\circ}$ C, if not, change the sensor; if it is, go to next step

(3) Remove the sensor from the compressor, if it still not solves, change the main board

(4) If all above steps done normally, it may be caused lack of refrigerant or damaged compressor or refrigerant system blocked or dirty or other gas get inside the system.

**F9: Three-phase electricity power phase sequence failure**

Solution:

(1) Check the 3-phase power connection lines are connected well or not

(2) Using the meter to measure the voltage (L1&N, L2&N, L3&N), all of them should be 220V, if not, correct the power supply, otherwise go to next step;

(3) If the power supply is corrected, change the main board

**P6: EEPROM failure**

Change the indoor mainboard

## 4. Air Handler unit

<b>1. Features</b>	<b>70</b>
<b>2. Specifications</b>	<b>71</b>
<b>3. Dimensions</b>	<b>72</b>
<b>4. Service Space</b>	<b>73</b>
<b>5. Wiring Diagrams</b>	<b>74</b>
<b>6. The Specification of Wiring</b>	<b>75</b>
<b>7. Field Wiring</b>	<b>76</b>
<b>8. Exploded View</b>	<b>77</b>
<b>9. Troubleshooting</b>	<b>78</b>

## 1. Features

- 1.1 Well-known compressor, LG & Copeland
- 1.2 Universal 24V communication connection for indoor and outdoor units control,
- 1.3 R410 environmental refrigerant, and it is matched with top-discharge unit and condensing unit.
- 1.4 Flexible installation for AHU, vertical and horizontal right installation is available.

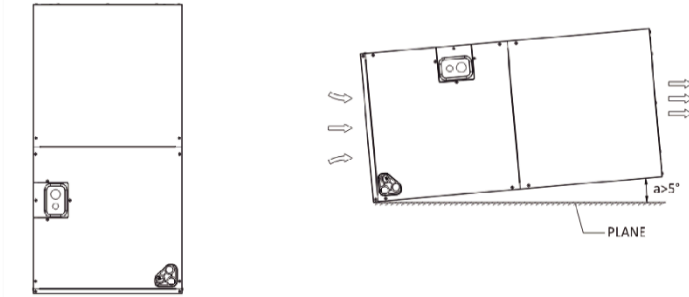

- 1.5 Easy controlled by thermostat and compatible with other manufacturer's products.



## 2. Specifications

Model			CAHi-36CNR1	CAHi-60CNR1
Power supply		V/Ph/ Hz	208-230V/1PH/60HZ	208-230V/1PH/60HZ
Cooling	Capacity	Btu/h	36000	60000
	Capacity	W	10500	16000
	Indoor Input	W	253	470
	Indoor Rated current	A	1.16	2.14
Indoor Max. input consumption		W	290	517
Indoor Max. current		A	1.33	2.34
Indoor coil	Number of row		2	3
	Fin spacing	mm	1.5	1.5
	Fin material		Hydrophilic Aluminium Fin	Hydrophilic Aluminium Fin
	Tube outside diameter	mm	Φ7	Φ7
	Tube material		Inner Screw	Inner Screw
	Coil length x height x width	mm	336*26.74*413 (X2)	378*40.11*443 (X2)
	Number of circuit		4	6
Indoor fan motor	Model		YDK130-6X	YDK250-6X-2
	Brand		Kangbao	Weiling
	Output	W	130	250
	Capacitor	μF	6	12
	Speed (Hi//Lo)	rpm	910/780	800/730
Indoor air flow		m <sup>3</sup> /h	1700	2500
Indoor noise level		dB(A)	51-56	51~57
Indoor dimension	Unit (WxHxD)	mm	460×774×520	500×970×550
	Packing (WxHxD)	mm	520×834×565	560×1030×595
Indoor weight	Net	kg	37	45
	Gross	kg	39	48
Operation temperature range		°C	16-32	16-32

### 3. Dimensions

CAHi-36CNR1 CAHi-60CNR1

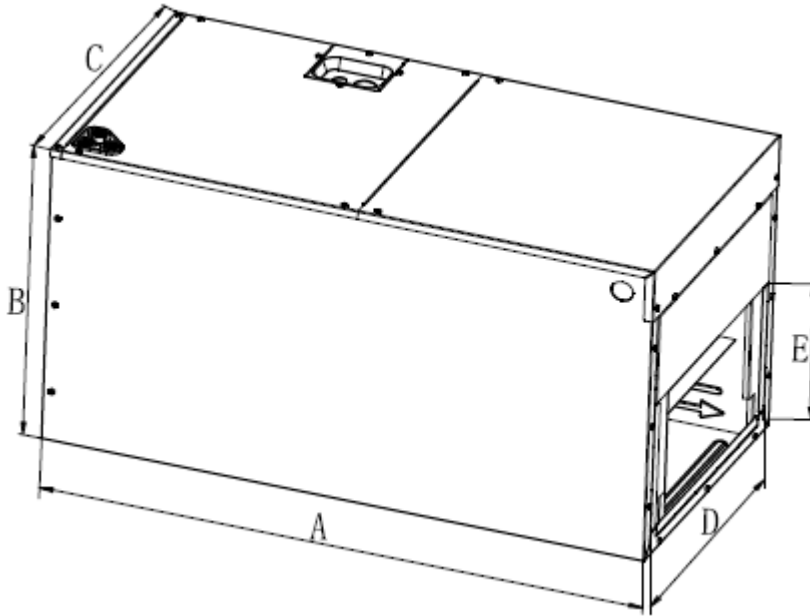

MODEL	Dimensions(mm)				
	A(Height)	B(Depth)	C(Width)	D	E
36	774	520	460	414	245
60	970 (1160)	550	500	454	266

## 4. Service Space

The air-handler unit should be installed in a location that meets the following requirements:  
INSTALLATION NOTES: .

1. Up-flow discharge , the installation of plug and drain pipe is shown in the left figure.
2. Horizontal-right discharge , the installation of plug and drain pipe is shown in the right figure.
3. The seal-plugs are supplied as accessories , and be screwed tightly only with hand.

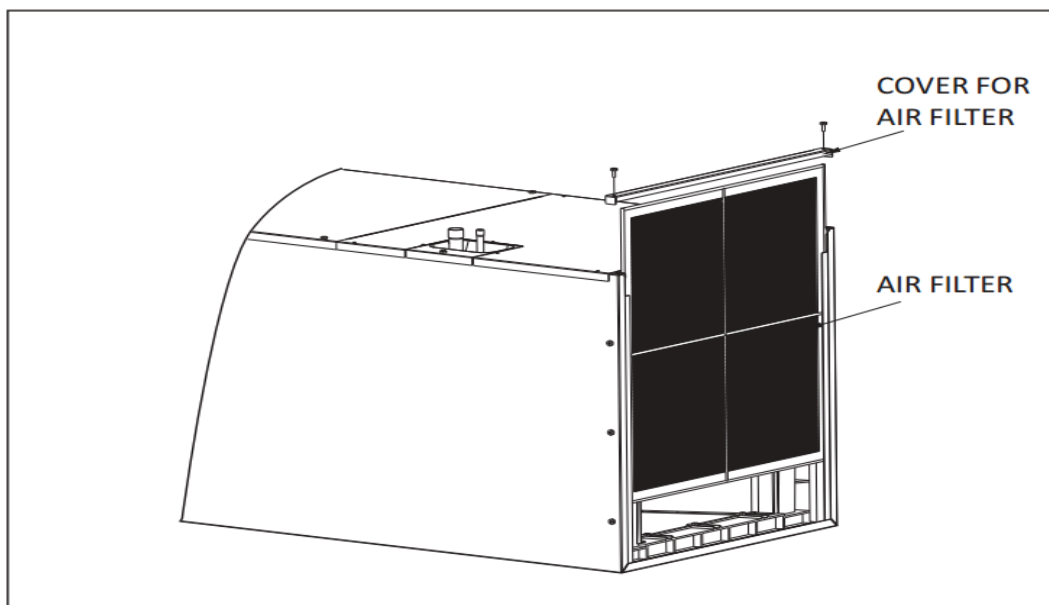
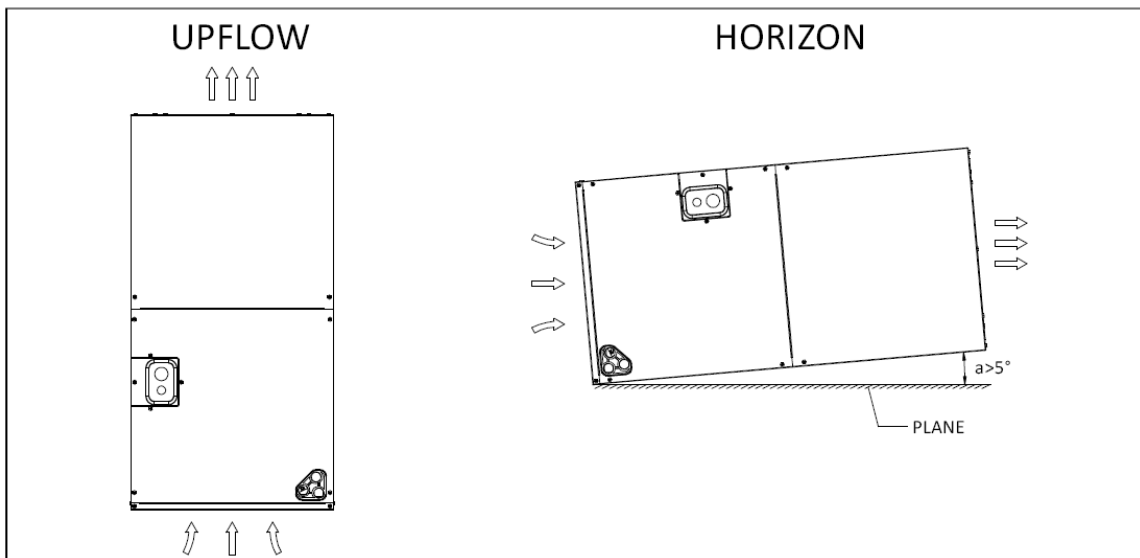

## 5. Wiring Diagrams

### CAHi-36CNR1 \ CAHi-60CNR1

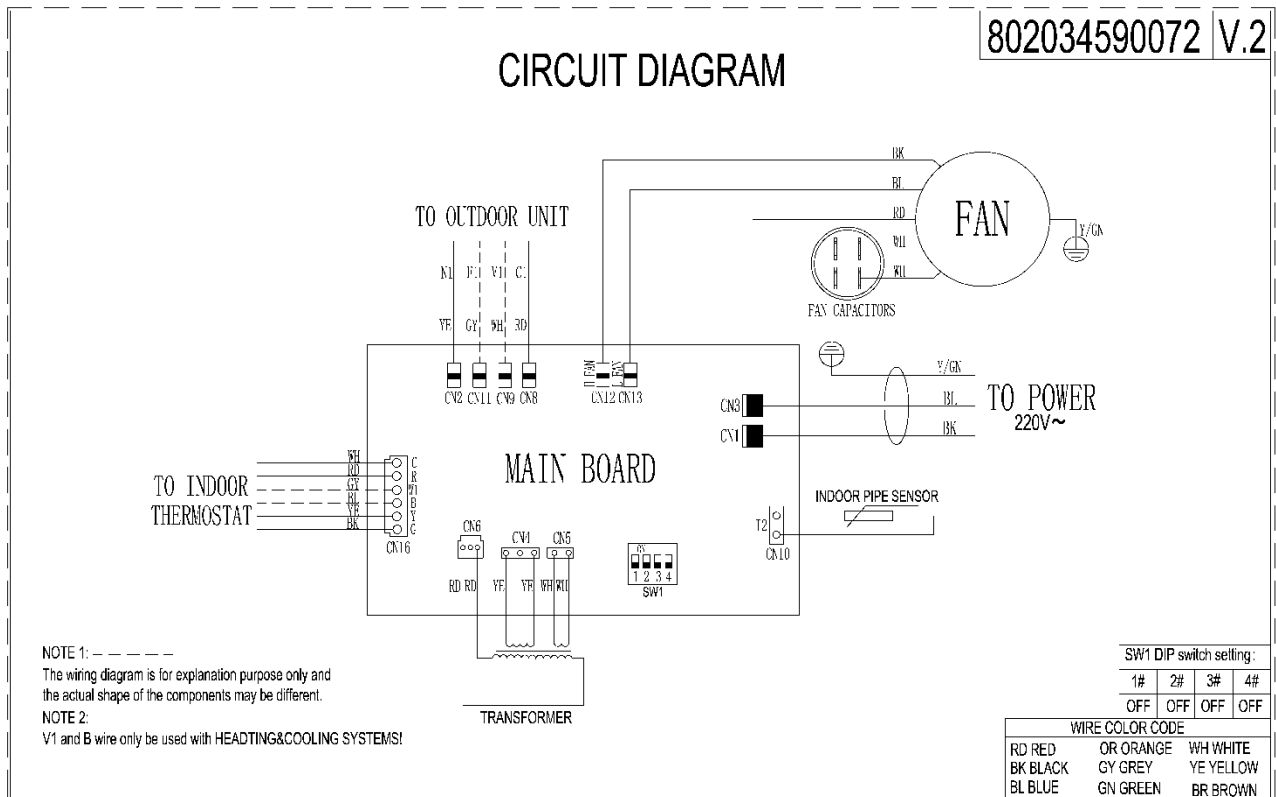

## 6.The Specification of Wiring

Single-phase for cooling only type, 220V

Capacity(Btu/h)		36000 Btu/h	60000 Btu/h
Power	Indoor	Single	
		220-230V,60Hz 1PH	
Power	Outdoor	Single	
		220-230V,60Hz 1PH	
Input Current Fuse		Indoor unit(A)	5A
Lines Gauge	Indoor Unit Power Line	Line Quantity	3
		Line Diameter(AWG)	18/1.0mm <sup>2</sup>
	Outdoor Unit Power Line	Line Quantity	3
		Line Diameter(AWG)	12/4.0mm <sup>2</sup>
	Outdoor-Indoor Signal Line	Line Quantity	2
		Line Diameter(AWG)	18/1.0mm <sup>2</sup>
	Thermostat Signal Line	Line Quantity	4
		Line Diameter(AWG)	18/1.0mm <sup>2</sup>

3-phase for cooling only type, 220V

Capacity(Btu/h)		60000 Btu/h	
Power	Indoor	Single	
		220-230V,60Hz 1PH\220-240,50Hz 1PH	
Power	Outdoor	Three	
		220-230V,60Hz 3PH	
Input Current Fuse		Indoor unit(A)	5A
Lines Gauge	Indoor Unit Power Line	Line Quantity	3
		Line Diameter(AWG)	18/1.0mm <sup>2</sup>
	Outdoor Unit Power Line	Line Quantity	4
		Line Diameter(AWG)	12/4.0mm <sup>2</sup>
	Outdoor-Indoor Signal Line	Line Quantity	2
		Line Diameter(AWG)	18/1.0mm <sup>2</sup>
	Thermostat Signal Line	Line Quantity	4
		Line Diameter(AWG)	18/1.0mm <sup>2</sup>

## 7. Field Wiring

1. To avoid the electric shock, please link the air conditioner with the ground. The plug in the air conditioner has joined the ground wiring, please don't change it freely.
2. The power socket is used as the air conditioner specially.
3. Don't pull the power wiring hard.
4. When linking the air conditioner with the ground; observe the local rules.
5. If necessary, use the power fuse or the circuit, breaker or the corresponding scale ampere.

When installing or repair the air condition, relate to system wiring, please operating as follows:

1. Tear down the seven bolts in the top cover, see in Figure below.
2. Hold the edge of the top condenser and extract out.
3. Install the top condenser in the reverse order of step 1 and 2.

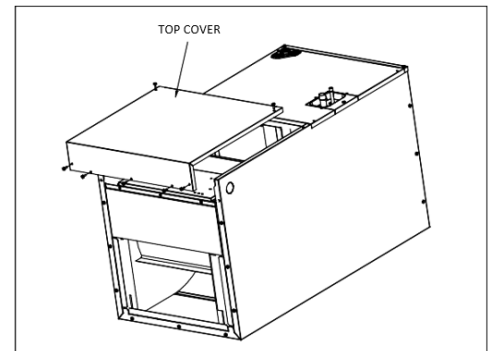
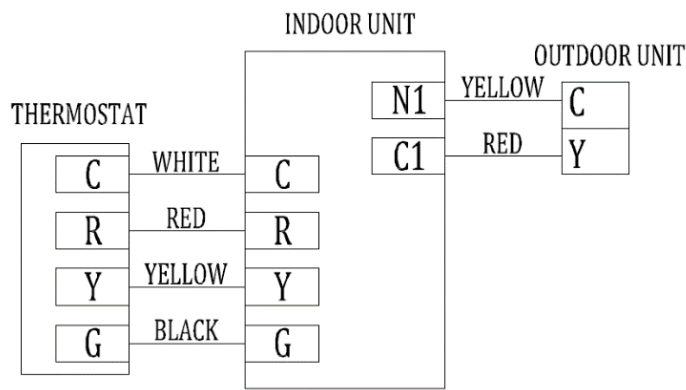

INDOOR UNIT OUTPUT WITH 24VAC 1.5A

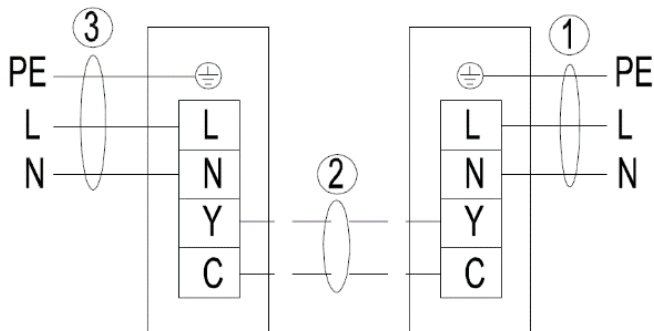

Outdoor unit Indoor unit  
Single-phase for cooling only type

## 8. Exploded View

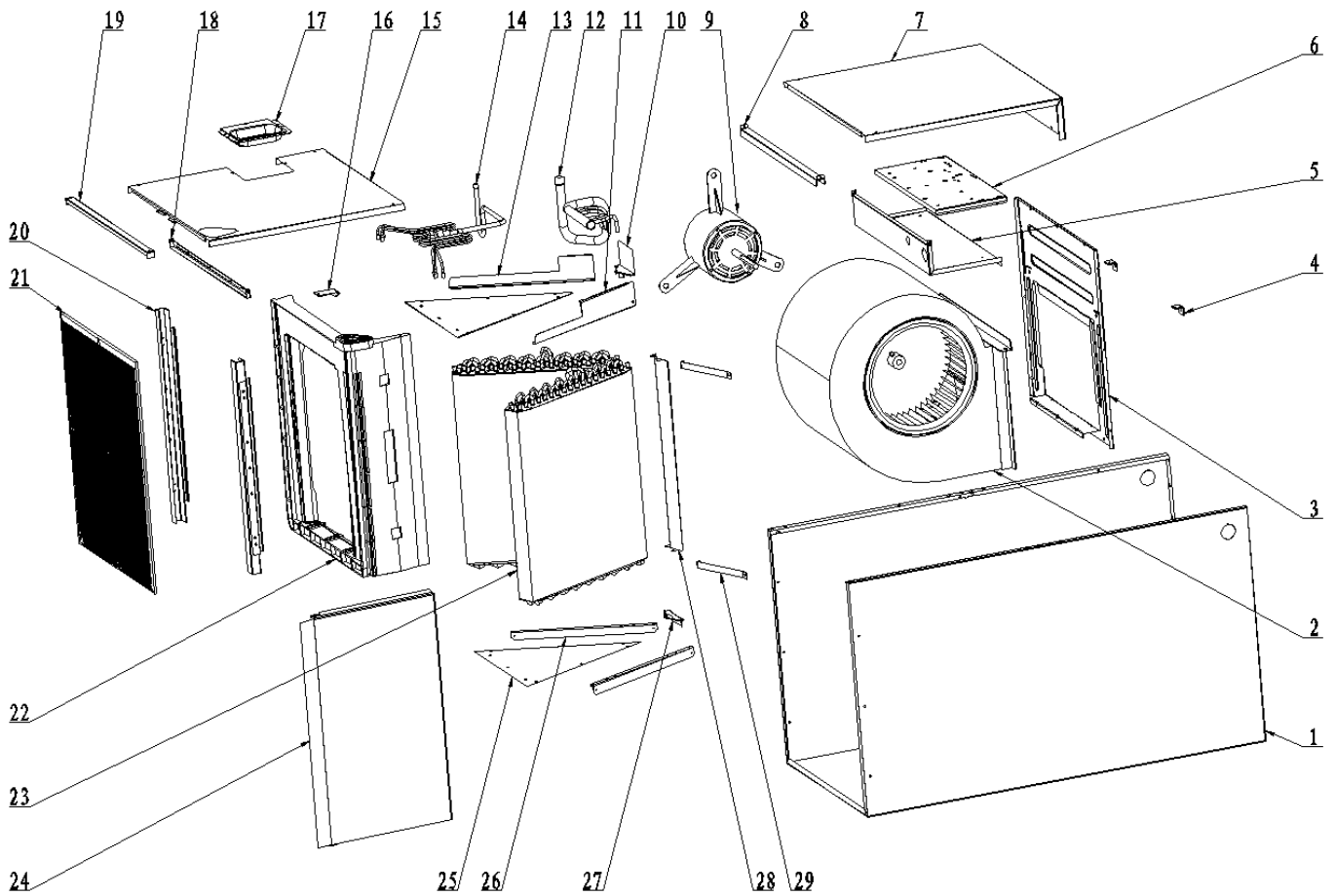

No.	Part Name	Qty	No.	Part Name	Qty
1	Chassis assembly	1	13	Evaporator Water Baffle #1	1
2	Right Volute Wind Wheel	1	14	Diverter Assembly	1
3	Fan Motor Fixing plate	1	15	Lower side plate assembly	1
4	Wind Wheel Fixed Block	2	16	Water pan fixed block	1
5	Electronic Control Fixing Plate Assy	1	17	Pipe Cover plate assembly	1
6	Electronic Control Components		18	Supporter	
6.1	Electronic Control Mounting Plate	1	19	Filter Cover plate	1
6.2	Main Control Board	1	20	Water pan supporter assembly	2
6.3	Transformer	1	21	Filter	1
6.4	Temperature Sensor	1	22	Water pan# 1	1
6.5	Fan Motor Capacitor	1	23	Evaporator	2
7	Upper side plate assembly	1	24	Water pan# 2	1
8	Middle Cross Beam Assembly	1	25	Evaporator Baffle	2
9	Indoor Motor	1	26	Evaporator Water Baffle #1	2
10	Evaporator Fixing Plate #2	1	27	Evaporator Fixing Plate #1	1
11	Evaporator Water Baffle #2	1	28	Evaporator Junction Plate	1
12	Air header Assembly	1	29	Water pan brace	1

## 9. Troubleshooting

### Indoor unit Fault code displayed

Fault Description	4LED fault indication	Digital display	Wired remote display
Three-phase power phase sequence fault		E0	E0
Indoor and outdoor unit communication failure	Timing lights flash	E1	E1
Temperature sensor (T1) fault	Running lights flash	E2	E2
Pipe temperature sensor in the evaporator (T2) fault	Running lights flash	E3	E3
Pipe temperature sensor in the evaporator (T2B) fault	Running lights flash	E4	E4
Outdoor unit failure	Warning lights flash slowly	E5	E5
The indoor unit EEPROM fault	Defrost lights flash slowly	E7	E7
Water over protection	Warning lights flash	EE	EE
Indoor unit with line controller communication failure		E9	E9
Note: The flash frequency for each of the above indicator is 2.5Hz, slow flashing frequency is 1Hz			

#### **E0: Three-phase electricity power phase sequence failure**

Solution:

- (1) Check the 3-phase power connection lines are connected well or not
- (2) Using the meter to measure the voltage (L1&N, L2&N, L3&N), all of them should be 220V, if not, correct the power supply, otherwise go to next step;
- (3) If the power supply is corrected, change the main board

#### **E1 : Indoor unit and outdoor unit communication failure**

Solution:

- (1) Check the communication cable between indoor unit and outdoor unit, if it is short connection or broken;
- (2) Check the communication cable is connected corrected or not, if not, correct it;
- (3) If the cable and connection are both correct, check the connected lines from communication terminal to main board are corrected or not, if not, correct it
- (4) If all the above steps are done, still not solve change the indoor or outdoor main board

#### **E2: Indoor ambient temp. sensor fault (T1 sensor)**

Solution:

- (1) Check the T1 sensor connection loosen or not, inset it firmly, if not solve, go to next step;
- (2) Take out the sensor, measure the resistance of the sensor, it is about 5K $\Omega$  at 25 $^{\circ}$ C, if not, replace it; if resistance normally, change the indoor main board.

#### **E3/E4: Indoor evaporator pipe temperature sensor (T2) failure**

Solution:

- (1) Check the T2 sensor connection loosen or not, inset it firmly, if not solve, go to next step;
- (2) Take out the sensor, measure the resistance of the sensor, it is about 5K $\Omega$  at 25 $^{\circ}$ C, if not, replace it; if resistance normally, change the indoor main board

#### **E5: Outdoor unit failure**

Check the detail of failure at the outdoor unit.

#### **E7: EEPROM failure**

Change the indoor mainboard



**E9: Indoor unit and wire controller communication failure**

Solution:

- (1) Check the connection between wired controller and main board is loosen or not, inset it firmly
- (2) Connect with a new wired controller, if not solve, change with a new communication cable
- (3) If all above steps done, it still not solves, change the indoor main board or transformer.

**EE: Water fulfilled protection (Alarm of condensing water overflow)**

Solution:

- (1) If the unit does not have water drainage pump:
  - a) Check the water level switch short connect or not, if not, short connect it, if it still not solves, change the main board
- (2) If the unit has water drainage pump:
  - d) Check the water level switch if it is connected well, inset it firmly; then check the switch is blocked or not, if it is blocked, replace it, otherwise go to next step
  - b) Check the connection between pump and main board if it is 220-240V, if it is, change the water pump; if not, change the indoor main board

## Part 3 Outdoor Units

<b>1. Specifications</b>	<b>81</b>
<b>2. Dimensions</b>	<b>82</b>
<b>3. Service Space</b>	<b>83</b>
<b>4. Wiring Diagrams</b>	<b>84</b>
<b>5. Electric Characteristics</b>	<b>86</b>
<b>6. Operation Limits</b>	<b>86</b>
<b>7. Exploded View</b>	<b>87</b>
<b>8. Sound Levels</b>	<b>89</b>
<b>9. Troubleshootings</b>	<b>90</b>

# 1.Specification

Model (Top Discharge Condensing Unit)			COT-24CNR1	COT-36CNR1	COT-48CNR1
Power supply		V-N-H Z	208-230V/1N/60Hz	208-230V/1N/60Hz	208-230V/1N/60Hz
Max. input consumption		W	2620	3600	6125
Max. current		A	13.2	23	30.93
Compressor	Model		PA240M2A-3MTU2	GVS295KAA	ABT042KTA
	Type		Rotary	Rotary	Scroll
	Brand		GMCC	LG	LG
	Qty		1	1	1
	Capacity	W	7220	8397	12368
	Input	W	2475	2933	3980
	Rated current(RLA)	A	11.75	13.6	17.5
	Thermal protector		Inner	Inner	Inner
	Refrigerant oil	ml	440	540	1360
Refrigerant			R410a	R410a	R410a
Outdoor fan motor	Model		YDK-160-6P2	YDK-160-6P2	YDK-230-6P2
	Brand		Lvzhi	Lvzhi	Lvzhi
	Drive	type	AC	AC	AC
	Qty		1	1	1
	Input	W	244	244	331
	Capacitor	uF	6μF/450V	6μF/450V	12μF/450V
	Speed	r/min	1100	1100	1095
Outdoor coil	Number of rows		1	1	1
	Tube pitch(a)x row pitch(b)	mm	21x13.37	21x13.37	21x13.37
	Fin spacing	mm	1.4	1.4	1.4
	Fin type		Unhydrophilic aluminum	Unhydrophilic aluminum	Unhydrophilic aluminum
	Coil length x height x width	mm	1428×588×13.37	1428×588×13.37	2150×798×13.37
	Number of circuits		2	2	5
	Tube O.D and type	mm	7.00 Inner groove tube	7.00 Inner groove tube	7.00 Inner groove tube
Outdoor noise level		dB(A)	65	65	63
Dimension	Bady (WxDxH)	mm	554×554×633	554×554×633	740×740×835
	Packing (WxDxH)	mm	575×575×660	575×575×660	760×760×875
Net/Gross weight		kg	46/49	46.5/49.5	92/96
Refrigerant charge		g	R410A/1200	R410A/1650	R410A/2000
Throttle type			Indoor Piston	Indoor Piston	Indoor Piston
Design pressure (high side/low side)		MPa	3.6/0.98	4.0/1.2	4.0/1.2
Refrigerant piping	Liquid side/ Gas side	mm	Φ9.52/Φ15.88	Φ9.52/Φ19.05	Φ9.52/Φ19.05
	Max. refrigerant pipe length	m	20	20	20
	Max. difference between outdoor unit and indoor unit	m	10	10	10
Connection wiring	Power wiring	mm <sup>2</sup>	3×2.5	3×4.0	3×4.0
	Signal wiring	mm <sup>2</sup>	2×0.75	2×0.75	4×0.75

Ambient temp	°C	16~43	16~43	16~43
--------------	----	-------	-------	-------

Model (Top Discharge Condensing Unit)		COT-60CNR1-60	COT-60CNR1	COT-48CXR1	COT-60CXR1	
Power supply	V-N-H Z	208-230V/1N/60Hz		208-230V/3N/60Hz		
Max. input consumption	W	5680	6900	6900	6400	
Max. current	A	25.8	34.85	20.85	16.81	
Compressor	Model	ATE518UN-Q9PK	ABT054KAA	C-SBP140H36A	ZP54KUE-TF5-52E	
	Type	Rotary	Scroll	Scroll	Scroll	
	Brand	HIGHLY	LG	SANYO	Copeland	
	Qty	1	1	1	1	
	Capacity	W	16000	15815	14100	15900
	Input	W	5400	4820	4800	4950
	Rated current(RLA)	A	23.6	21.5	15.5	15.1
	Thermal protector		83	Inner	1700	Inner
	Refrigerant oil	ml	Inner	1360	1700	1242
Refrigerant		R410a	R410a	R410a	R410a	
Outdoor fan motor	Model	YDK-230-6P2	YDK-230-6P2	YDK-230-6P2	YDK-230-6P2	
	Brand	Lvzhi	Lvzhi	Lvzhi	Lvzhi	
	Drive	type	AC	AC	AC	AC
	Qty		1.00	1	1	1
	Input	W	331	331	331	331
	Capacitor	uF	12μF/450V	12μF/450V	12μF/450V	12μF/450V
	Speed	r/min	1095	1095	1095	1095
Outdoor coil	Number of rows		1	1	1	1
	Tube pitch(a)x row pitch(b)	mm	21x13.37	21x13.37	21*25.6	21*25.6
	Fin spacing	mm	1.4	1.4	1.4	1.4
	Fin type		Unhydrophilic luminum			
	Coil length x height x width	mm	2150×798×13.3 7	2150×798×13.3 7	2150×798×25. 6	2148×798×25. 6
	Number of circuits		5	5	5	5
	Tube O.D and type	mm	7.00 Inner groove tube	7.00 Inner groove tube	7.00 Inner groove tube	7.00 Inner groove tube
Outdoor noise level	dB(A)	65	65	63	65	
Dimension	Bady (WxDxH)	mm	740×740×835	740×740×835	740×740×835	740×740×835
	Packing (WxDxH)	mm	760×760×875	760×760×875	760×760×875	760×760×875
Net/Gross weight	kg	74.5/78	74.5/79	83.8/88.05	89/94	
Refrigerant charge	g	R410A/2750g	R410A/2100	R410A/2000	R410A/2100	
Throttle type		Indoor Piston	Indoor Piston	Indoor Piston	Indoor Piston	
Design pressure (high side/low side)	MPa	4.2/1.5	4.0/1.2	4.0/1.2	4.0/1.2	
Refrigerant piping	Liquid side/ Gas side	mm	Φ9.52/Φ19.05	Φ9.52/Φ19.05	Φ9.52/Φ19.05	Φ9.52/Φ19.05
	Max. refrigerant pipe length	m	20	20	20	20
	Max. difference between outdoor unit and indoor unit	m	10	10	10	10
Connection wiring	Power wiring	mm <sup>2</sup>	3×2.5	3×6.0	3×4.0	3×4.0
	Signal wiring	mm <sup>2</sup>	2×0.75	4×0.75	4×0.75	4×0.75
Ambient temp	°C	16~43	16~43	21~43	21~43	

## 2.Dimensions

Applicable for 18-60 series

Unit Model	Dimensions(mm)			Refrigerant Connection Line Size(mm)		
	A	B	C	Liquid( $\phi$ )		Vapor( $\phi$ )
				LF	RF	
24	633	554	554	9.52		15.88
36	633	554	554	9.52	12.7	19.05
	633	740	740			
	835	554	554			
48	835	740	740	9.52	12.7	19.05
60	835	740	740	9.52	12.7	19.05

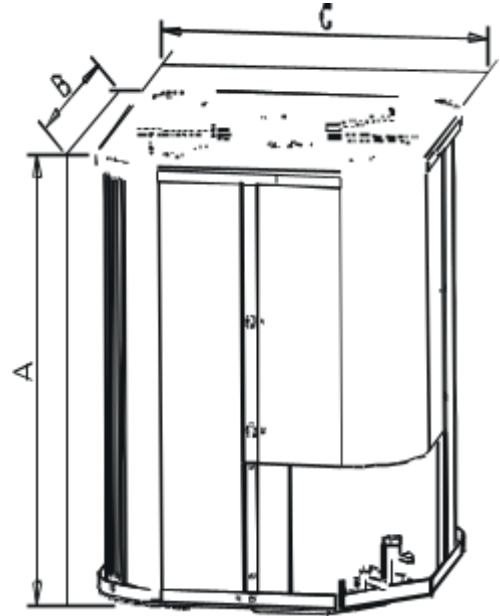

### 3. Typical Installation

#### TYPICAL INSTALLATION

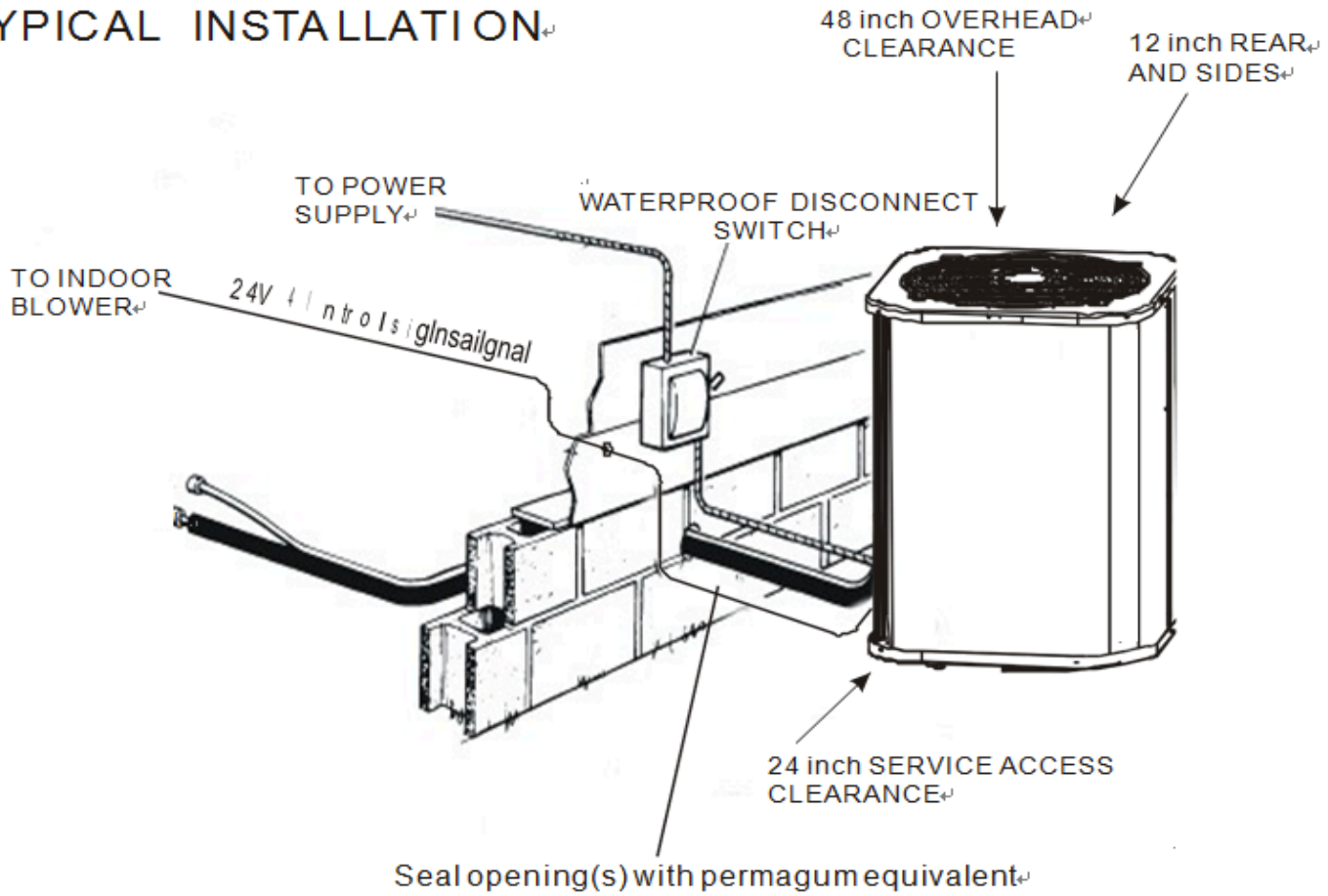

# 4.Wiring Diagrams

COT-24CNR1 COT-36CNR1

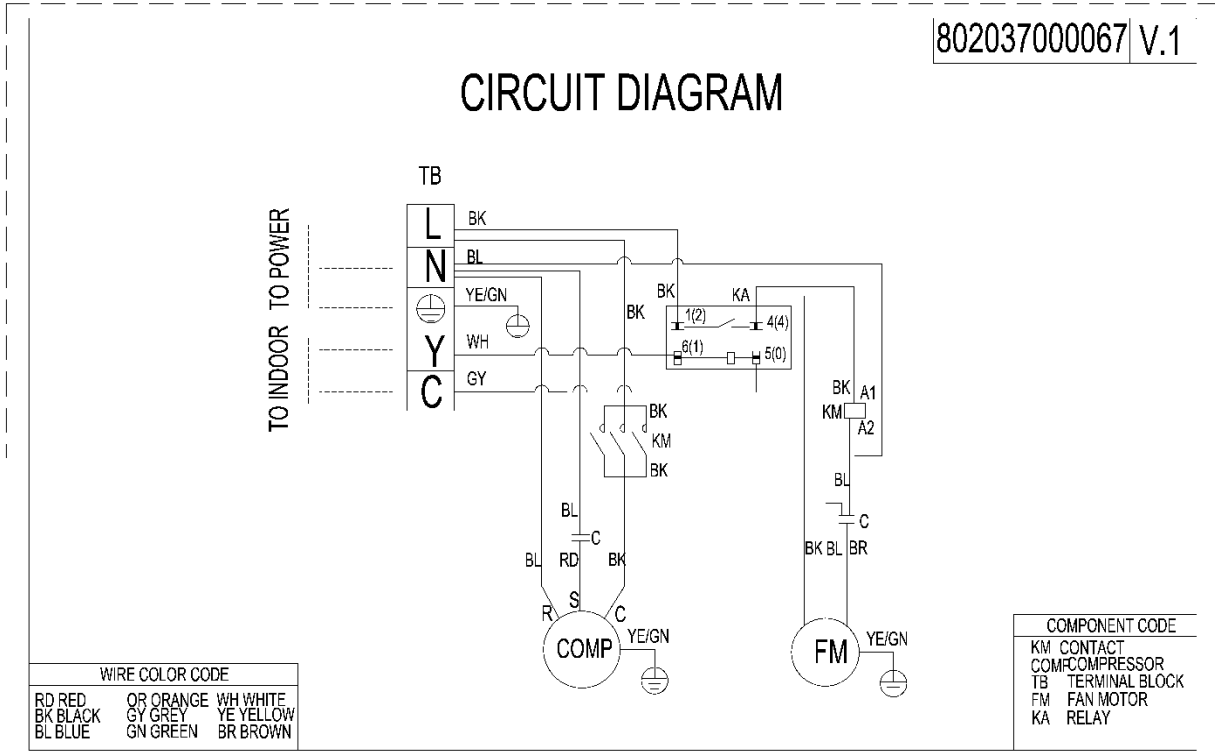

COT-48CNR1 COT-60CNR1

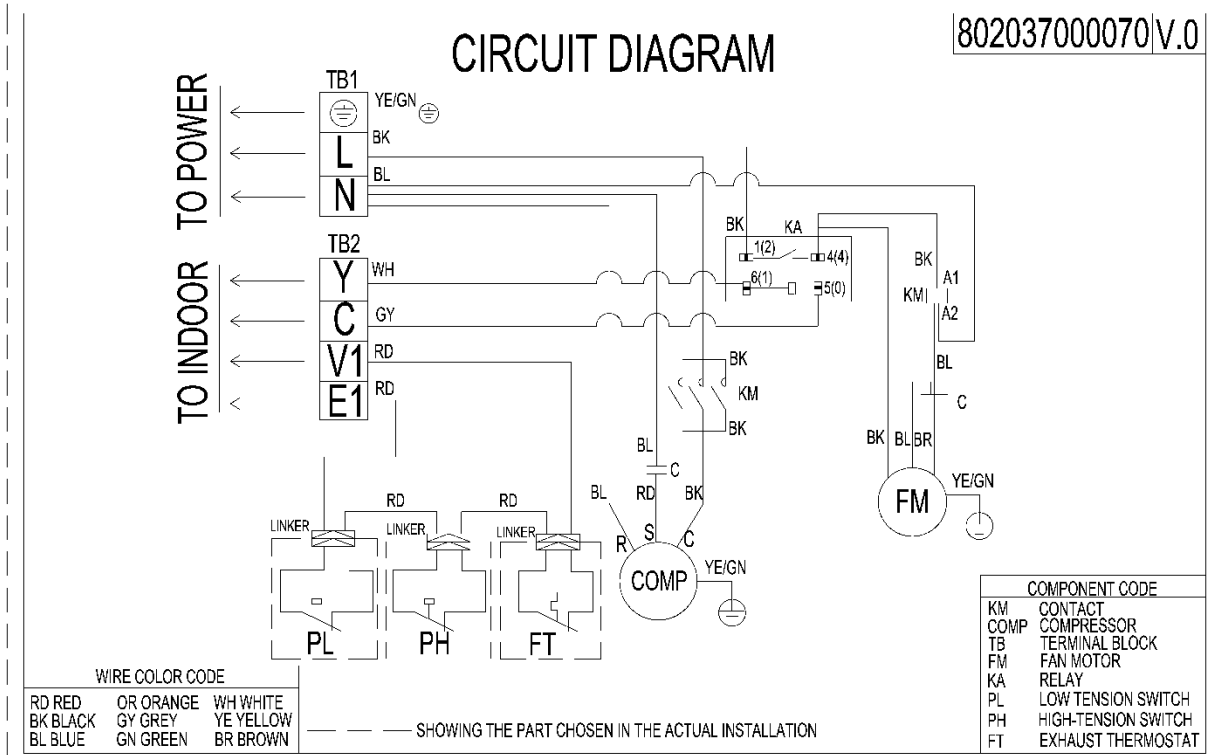



COT-48CXR1 COT-60CXR1

802037000069 V.0

CIRCUIT DIAGRAM

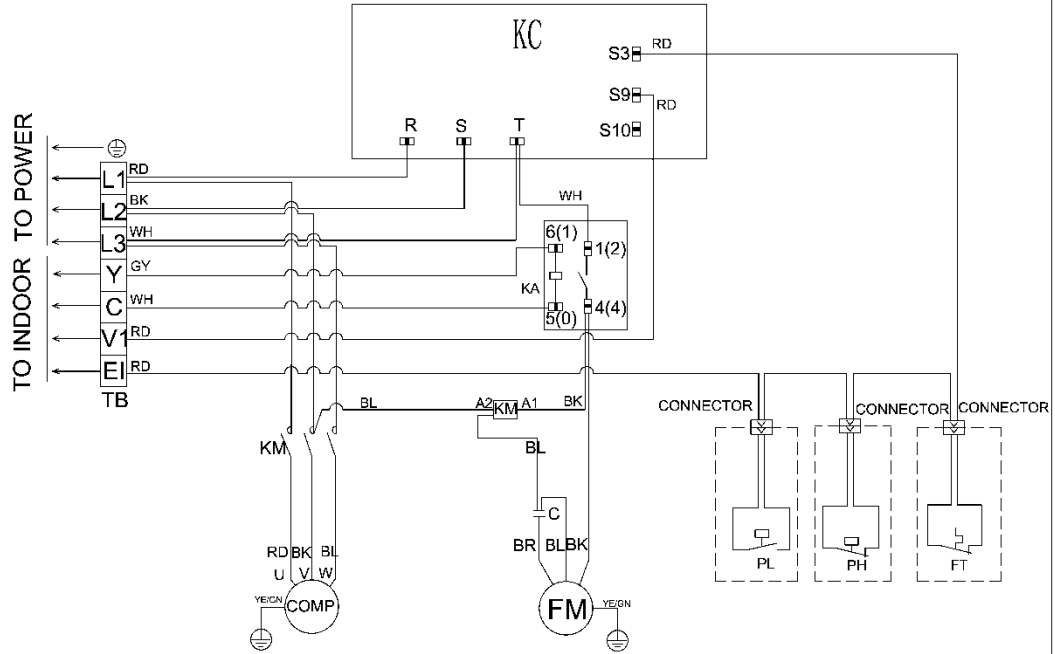

WIRE COLOR CODE	NOTES	COMPONENT CODE
RD RED OR ORANGE WH WHITE BK BLACK GY GREY YE YELLOW BL BLUE GN GREEN	1.The units should use unattached power switch,use stated-cross-section wire to and use matching-spec breaker.	KM CONTACT COMP COMPRESSOR TB TERMINAL BLOCK KC Anti-phase protector KA RELAY FM FAN MOTOR PL LOW PRESSURE SWITCH PH HIGH PRESSURE SWITCH FT EXHAUST SWITCH
<b>WIRE INFORMATION</b>	2.Use the fuse within the specified scope,don't use iron wire or brass wire to replace.	
— FACTORY CONNECTION - - - - - PROJECT CONNECTION - - - - - PRACTICALITY EXTERIOR - - - - - DASHED CIRCLE	3.The units should install stated-cross-section earth wire.Make sure it earth unfaillingly.	

## 5. Electric Characteristics

Model	Outdoor Unit			
	Hz	Voltage	Min.	Max.
COT-24CNR1	60	208-230V	187V	244V
COT-36CNR1	60	208-230V	187V	244V
COT-48CNR1	60	208-230V	187V	244V
COT-48CXR1	60	208-230V	187V	244V
COT-60CNR1	60	208-230V	187V	244V
COT-60CXR1	60	208-230V	187V	244V

## 6. Operation Limits

Operation mode	Outdoor temperature(°C)	Room temperature(°C)
Cooling operation	18~43	17~30
Heating operation	-7~24	17~30



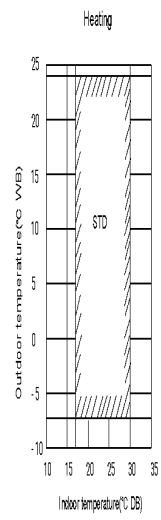
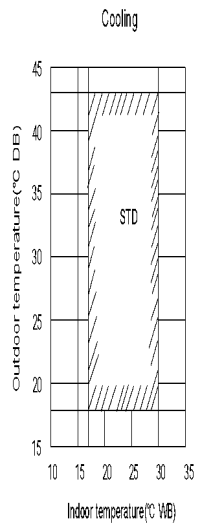

## 7. Exploded View

COT-24CNR1 COT-36CNR1 COT-48CNR1 COT-60CNR1

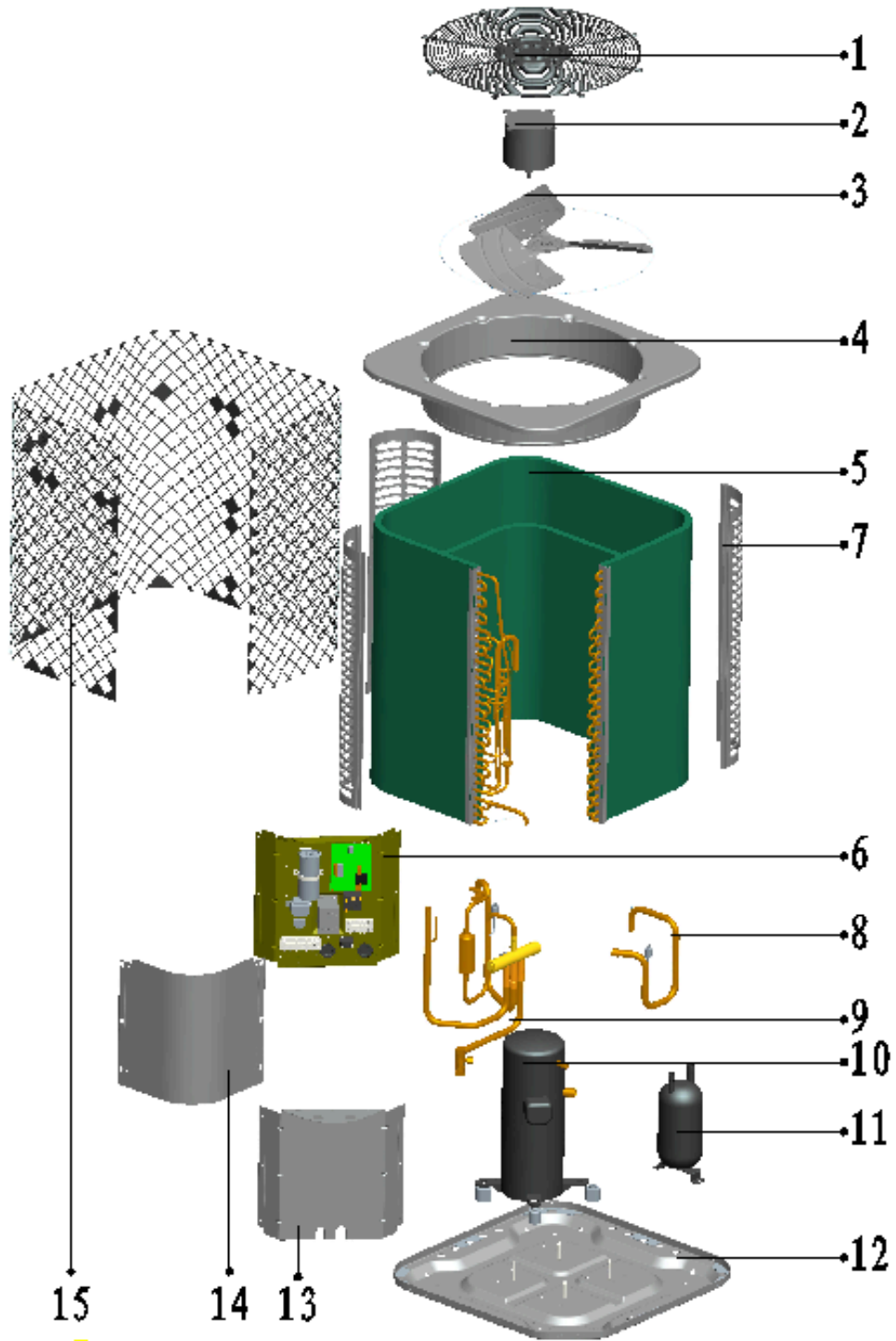

1	Top net	1
2	Uniaxial outdoor motor	1
3	Propeller fan	1
4	Top cover assembly	1
5	Condenser assembly	1
5.1	Condenser ssembly	1
5.2	Condenser input pipe assembly	1
5.3	Condenser output pipe assembly	1
5.4	Weld assembly for high tempreture valve	1
5.4.1	Block valve body 2	1
6	Electronic components	1
6.1	Electric install board weld assembly	1
6.2	Electric waterproof box	2
6.3	Outdoor PC board assembly	1
6.4	Contactora	1
6.5	Exhaust temperature controller	1
6.6	Fan capacitor	1
6.7	Discharge temp sensor	1
6.8	Condenser temp sensor	1
6.9	Terminal board	1
6.10	Terminal board	1
6.11	Wire for 4-valve	1
7	Support board	3
8	Suction pipe weld assembly	1
8.1	Compressor suction pipe	1
10.2	Low-pressure switch	1
9	4-Ways valve weld assembly	1
9.1	4-Ways valve	1
9.2	4-Ways valve connected pipe 1	1
9.3	4-Ways valve connected pipe 2	1
9.4	4-Ways valve connected pipe 1	1
9.5	Block valve body (04)	1
9.6	Discharge pipe weld assembly	1
9.6.1	Compressor discharge pipe	1
9.6.2	Compressor discharge pipe 1	1
11.3	High-pressure switch	1
9.6.4	Probe pipe	1
9.6.5	Silencer	1
10	Compressor	1
11	Vapour-liquid separator	1
12	Chassis assembly	1
13	Under side panel	1
14	Top panel	1
15	Protection grill	1

## 8.Sound Levels

24000Btu/h~60000Btu/h

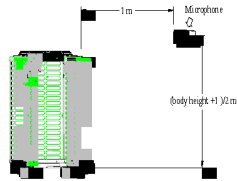

**Note:** H= 0.5 × height of outdoor unit

**Note:** The point A is in the middle of the whole outdoor panel.

Model	Noise level dB(A)
COT-24CNR1	56
COT-36CNR1	65
COT-48CNR1	65
COT-48CXR1	65
COT-60CNR1	65
COT-60CXR1	65

## 9. Troubleshooting

### 9.1 Fault indicator of outdoor unit

The meaning of the fault indicator:

Display content		State description
No alarm: Green light flashes Yellow lights	Green light slow flash	Normal standby
	Green light normally on	Normal operation
System Alarm: Green light slow flash Yellow light flashing	(T3)Temperature sensor fault	Yellow light flashes 2 times every 8s
	(T5)Temperature sensor fault	Yellow light flashes 8 times every 8s
	Low pressure alarm	Yellow light flashes 6 times every 8s
	High pressure alarm	Yellow light flashes 1 times every 8s
	(T3)High temperature protection	Yellow light flashes 9 times every 8s
	High exhaust temperature protection	Yellow light flashes 5 times every 8s
System lock: Green light go out Yellow light normally on	3 high/low voltage protection in 20 minutes	It needs to be reenergized and it needs to work
	Exhaust temperature is too high for 3 times within 20 minutes	
	T3 high temperature protection 3 times within 20 minutes	

## 9.2 Flow chart of troubleshooting

### 1) Evaporator temperature sensor fault

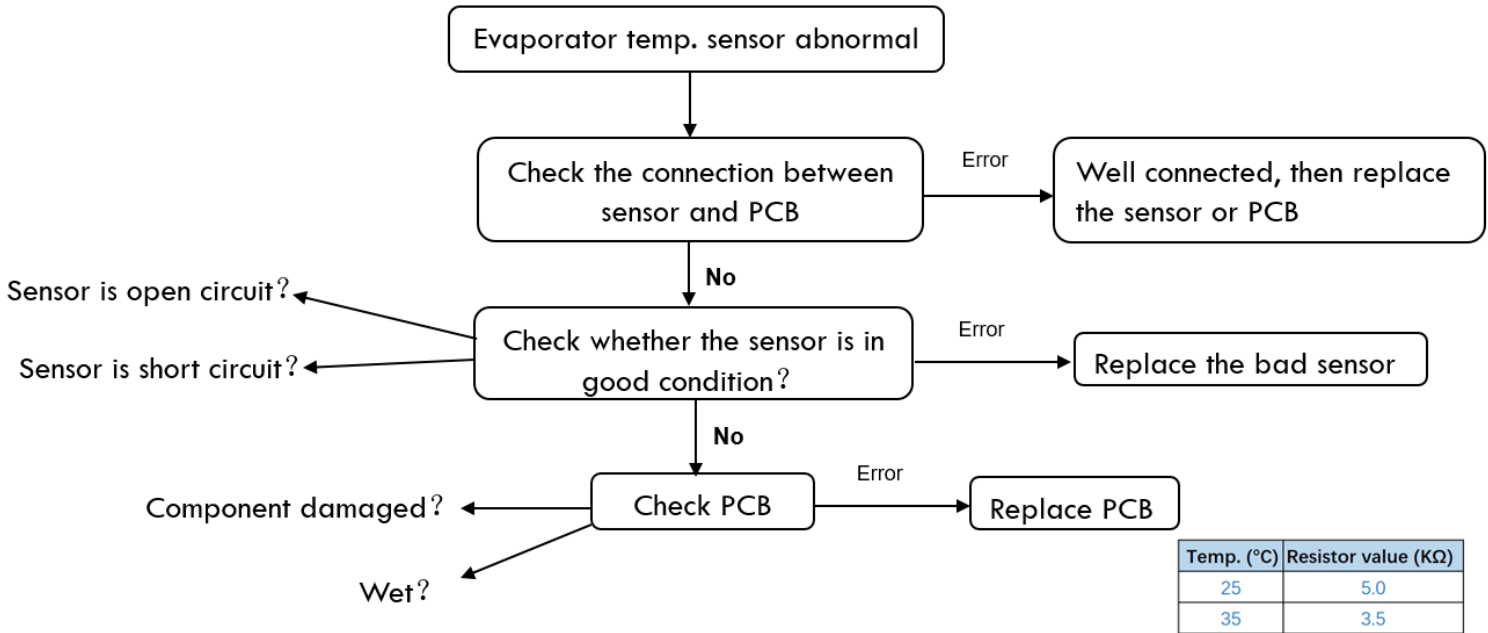

### 2) Evaporator high temperature protection(For heating mode)

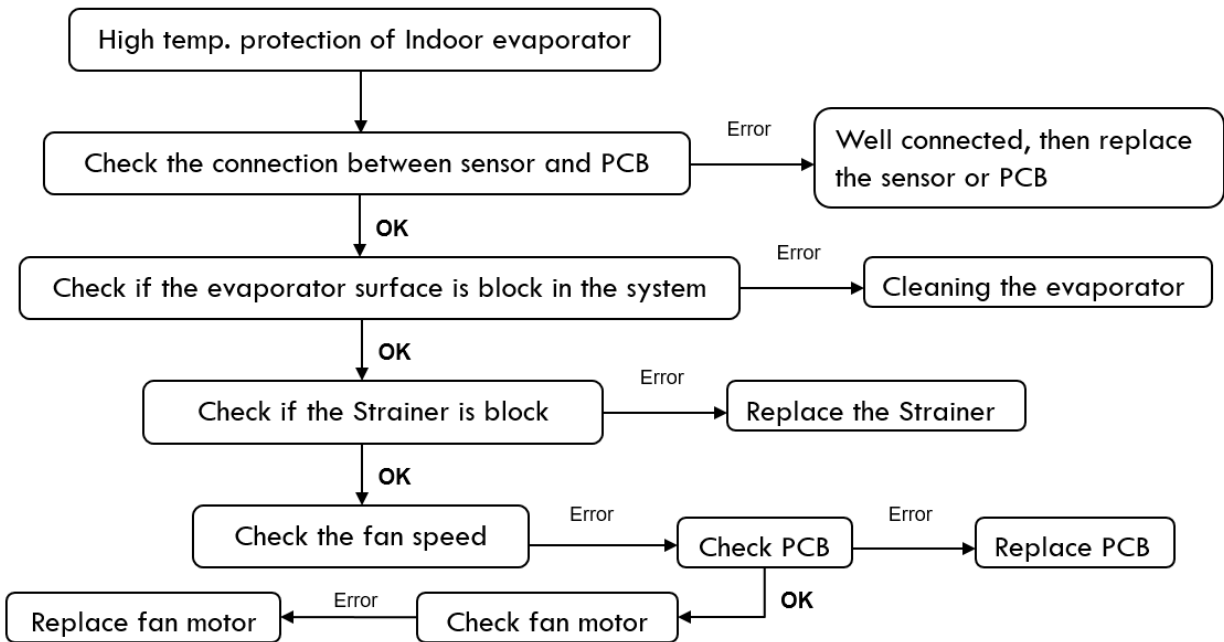

### 3) Evaporator low temperature protection(For cooling mode)

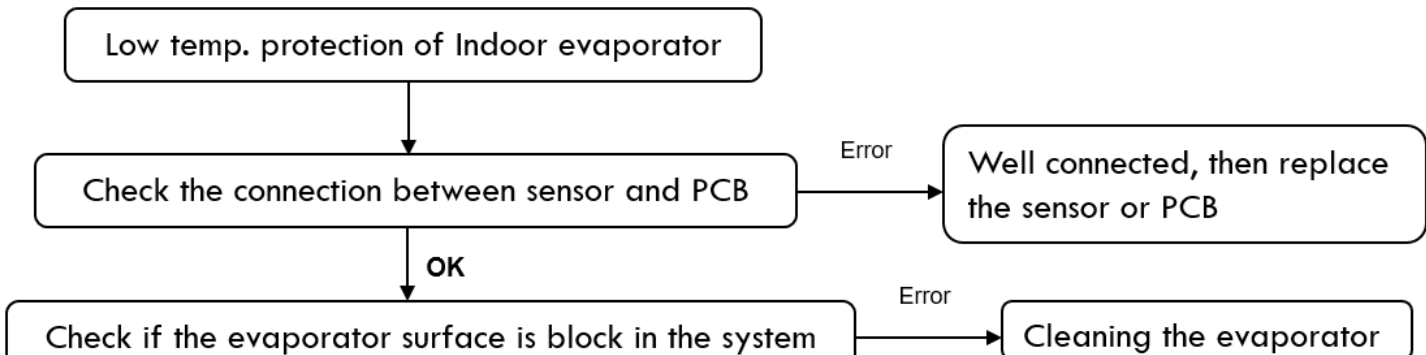



#### 4)T3 Condenser Temperature sensor fault

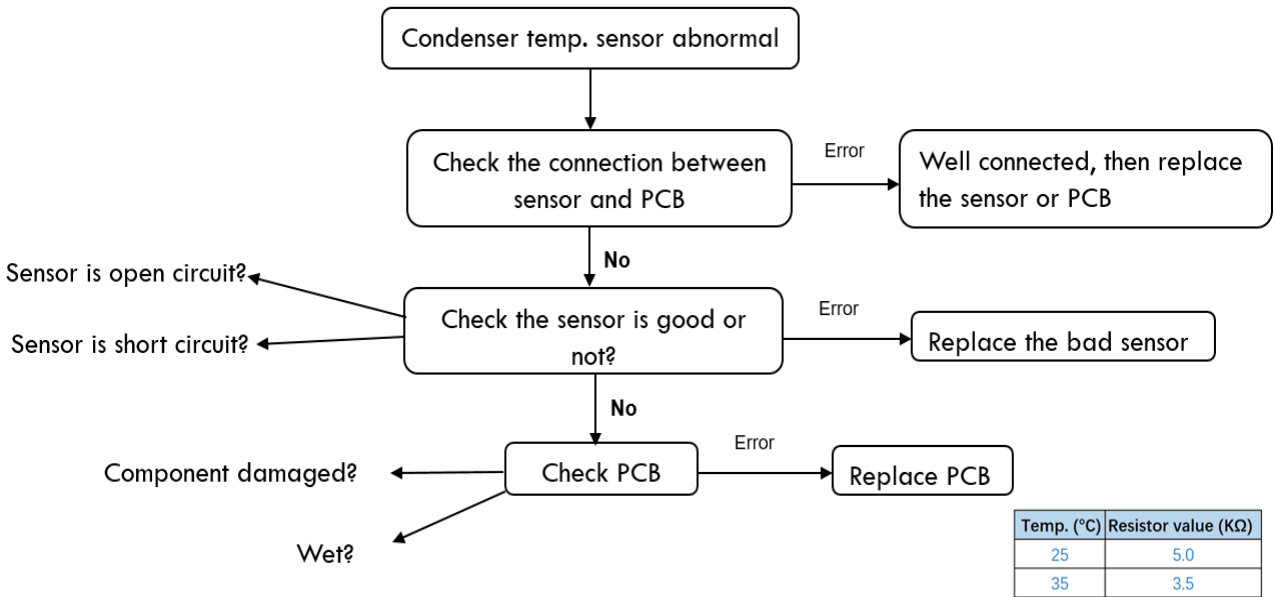

#### 5)T5 discharge temperature sensor fault

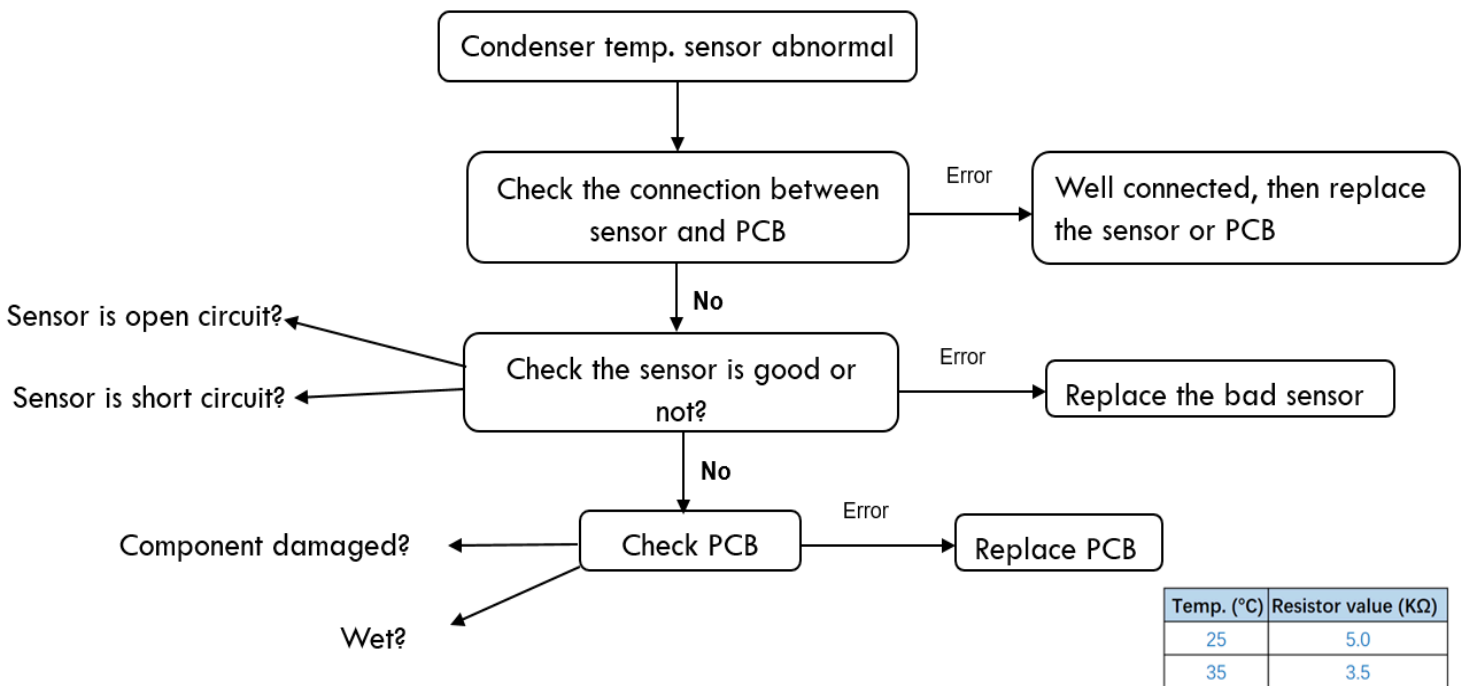

#### 6)Low pressure alarm

Low Pressure alarm



7) High pressure alarm

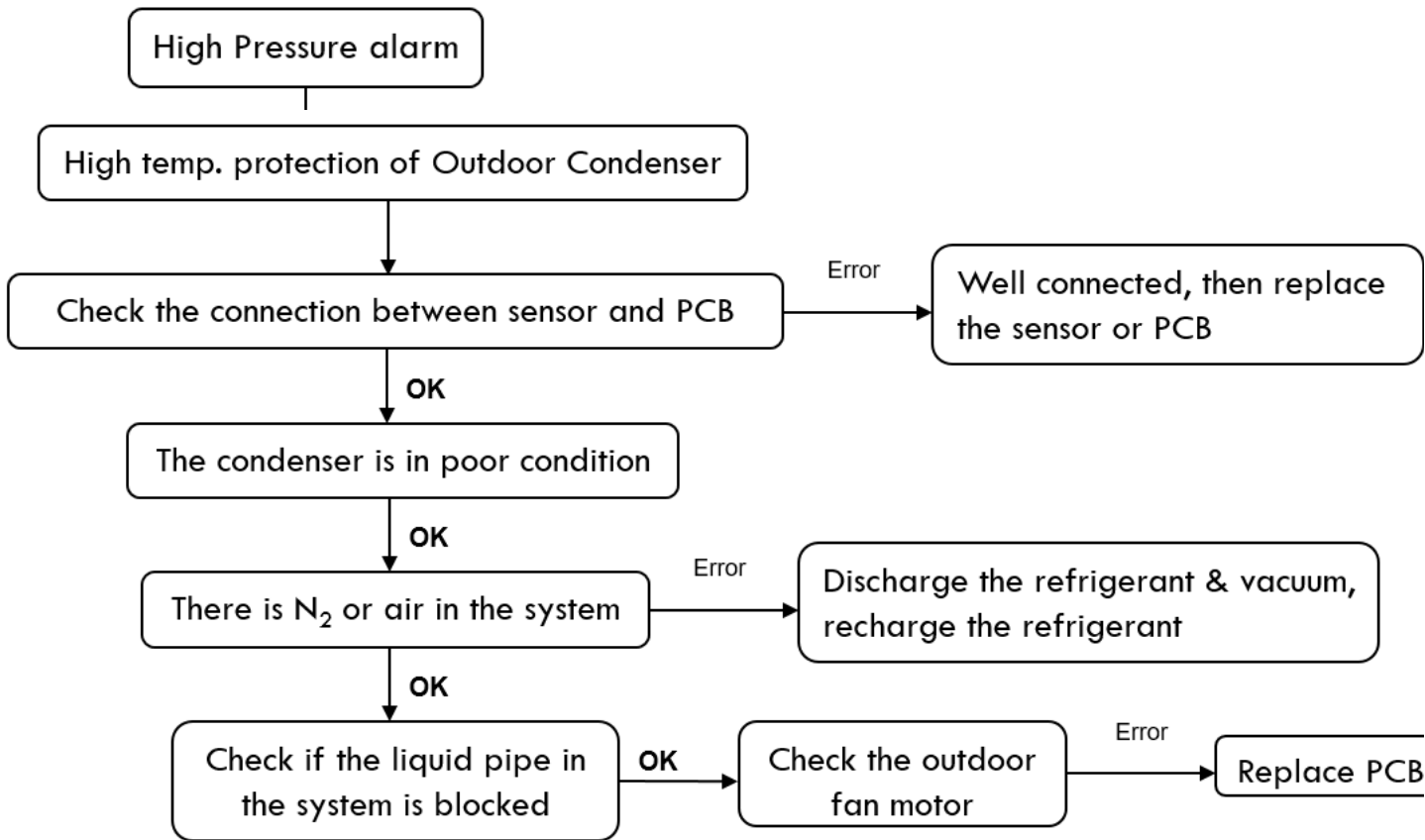

8) T3 High temperature protection

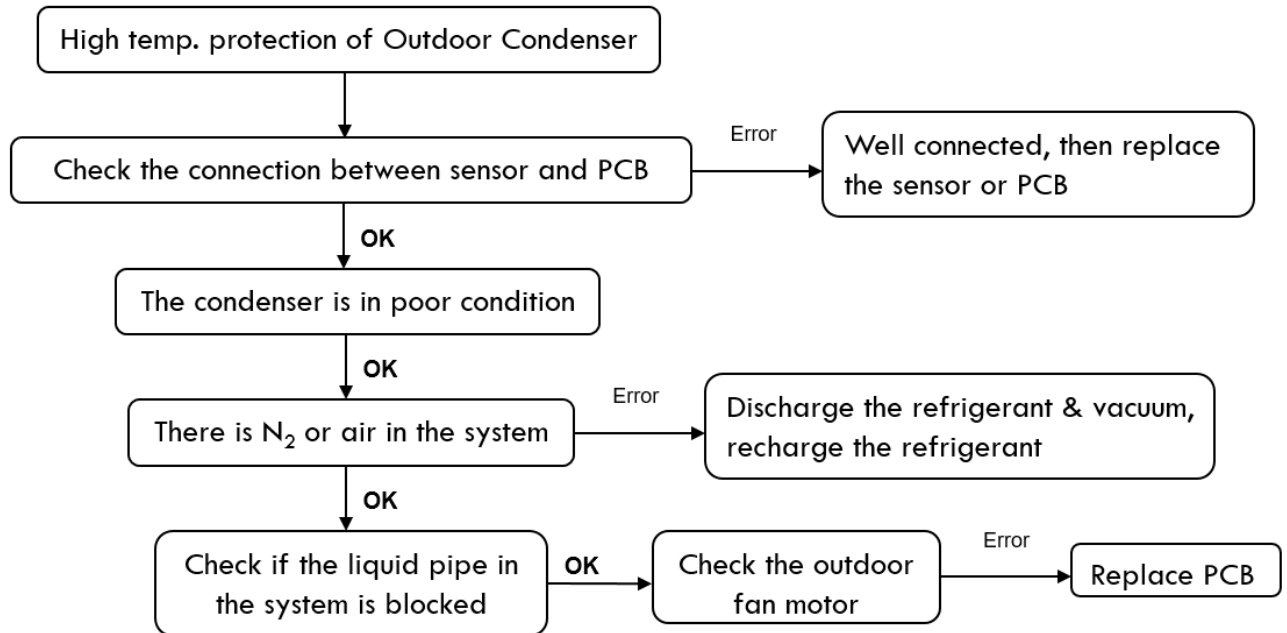

9) High exhaust temperature protection

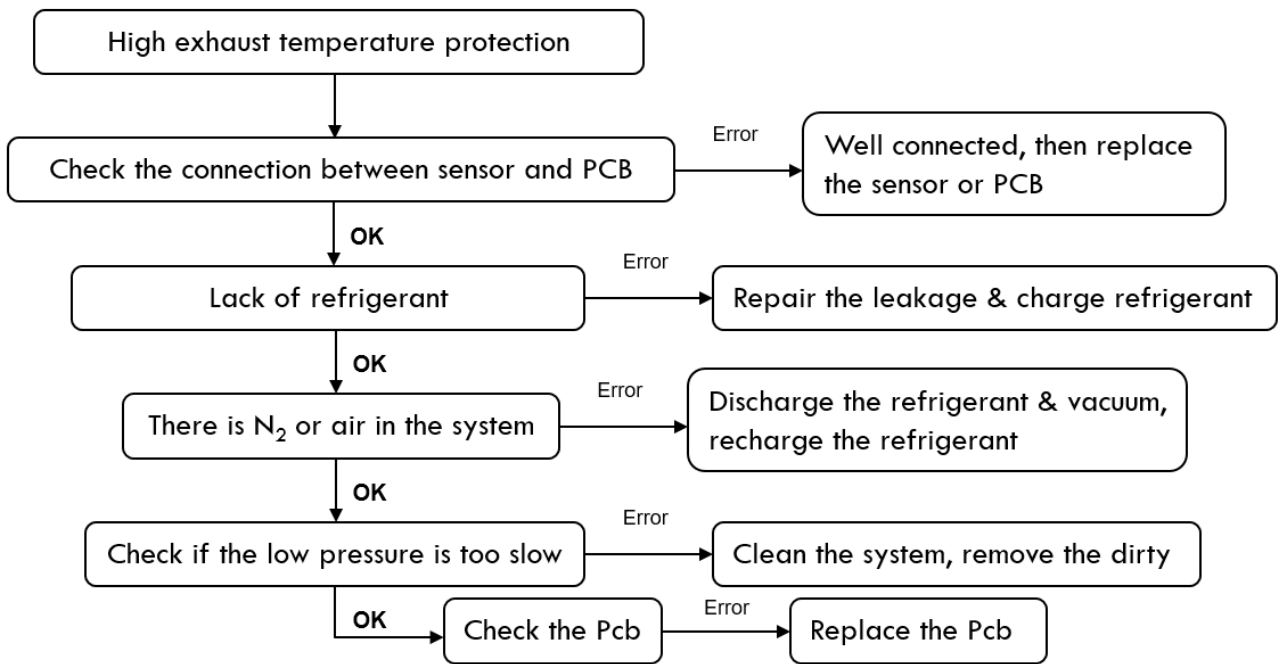

## Part 4 Installation

<b>1. Precaution on Installation</b>	<b>97</b>
<b>2. Vacuum Dry and Leakage Checking</b>	<b>98</b>
<b>3. Additional Refrigerant Charge</b>	<b>100</b>
<b>4. Water Drainage</b>	<b>101</b>
<b>5. Insulation Work</b>	<b>104</b>
<b>6. Test Operation</b>	<b>106</b>

# 1. Precaution on Installation

1.1. Measure the necessary length of the connecting pipe, and make it by the following way.

- a. Connect the indoor unit at first, then the outdoor unit.  
Bend the tubing in proper way. Do not harm them.

**CAUTIONS:**

- Daub the surfaces of the flare pipe and the joint nuts with frozen oil, and wrench it for 3~4 rounds
  - With hands before fasten the flare nuts.
- Be sure to use two wrenches simultaneously when you connect or disconnect the pipes.

Pipe gauge	Tightening torque	Flare dimension A		Flare shape
		Min (mm)	Max	
Φ6.4	15~16N.m (153~163 kgf.cm)	8.3	8.7	
Φ9.5	25~26N.m (255~265kgf.cm)	12.0	12.4	
Φ12.7	35~36N.m (357~367kgf.cm)	15.4	15.8	
Φ15.9	45~47N.m (459~480 kgf.cm)	18.6	19.1	
Φ19.1	65~67N.m (663~684kgf.cm)	22.9	23.3	

- b. The stop value of the outdoor unit should be closed absolutely (as original state). Every time you connect it, first loosen the nuts at the part of stop value, then connect the flare pipe immediately (in 5 minutes). If the nuts have been loosened for a long time, dusts and other impurities may enter the pipe system and may cause malfunction later. So please expel the air out of the pipe with refrigerant before connection.
- c. Expel the air after connecting the refrigerant pipe with the indoor unit and the outdoor unit. Then fasten the nuts at the repair-points.

1.2. Locate The Pipe

- a. Drill a hole in the wall (suitable just for the size of the wall conduit), then set on the fittings such as the wall conduit and its cover.
- b. Bind the connecting pipe and the cables together tightly with binding tapes. Do not let air in, which will cause water leakage by condensation.
- c. Pass the bound connecting pipe through the wall conduit from outside. Be careful of the pipe allocation to do no damage to the tubing.

1.3. Connect the pipes.

1.4. Then, open the stem of stop values of the outdoor unit to make the refrigerant pipe connecting the indoor unit with the outdoor unit in fluent flow.

1.5. Be sure of no leakage by checking it with leak detector or soap water.

1.6. Cover the joint of the connecting pipe to the indoor unit with the soundproof / insulating sheath (fittings), and bind it well with the tapes to prevent leakage.

## 2. Vacuum Dry and Leakage Checking

2.1 Vacuum Dry: use vacuum pump to change the moisture (liquid) into steam (gas) in the pipe and discharge it out of the pipe to make the pipe dry. Under one atmospheric pressure, the boiling point of water (steam temperature) is 100°C. Use vacuum pump to make the pressure in the pipe near vacuum state, the boiling point of water falls relatively. When it falls under outdoor temperature, the moisture in the pipe will be vaporized.

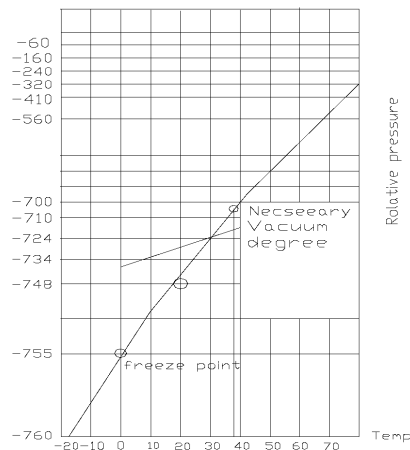

### 2.2 Vacuum dry procedure

There are two methods of vacuum dry due to different construction environment: common vacuum dry, special vacuum dry.

#### ①. Common vacuum dry procedure

- Vacuum dry (for the first time)---connect the all-purpose detector to the inlet of liquid pipe and gas pipe, and run the vacuum pump more than two hours (the vacuum pump should be below -755mmHg)
- If the pump can't achieve below -755mmHg after pumping 2 hours, moisture or leakage point will still exist in the pipe. At this time, it should be pumped 1 hour more.
- If the pump can't achieve -755mmHg after pumping 3 hours, please check if there are some leakage points.
- Vacuum placement test: place 1 hour when it achieves -755mmHg, pass if the vacuum watch shows no rising. If it rises, it shows there's moisture or leakage point.
- Vacuuming from liquid pipe and gas pipe at the same time.
- Sketch map of common vacuum dry procedure.

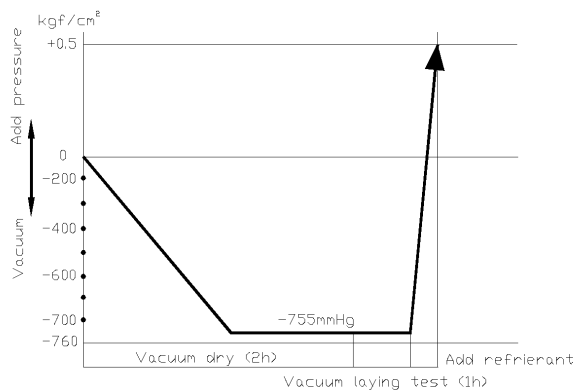

#### ②. Special vacuum dry procedure

- This vacuum dry method is used in the following conditions:
- There's moisture when flushing the refrigerant pipe.
- Rainwater may enter into the pipe.
- Vacuum dry for the first time ..... 2h pumping

③. Vacuum destroy for the second time ..... Fill nitrogen to 0.5Kgf/cm<sup>2</sup>

Because nitrogen is for drying gas, it has vacuum drying effect during vacuum destroy. But if the moisture is too much, this method can't dry thoroughly. So, please pay more attention to prevent water entering and forming condensation water.

④. Vacuum dry for the second time.....1h pumping

Determinant: Pass if achieving below -755mmHg. If -755mmHg can't be achieved in 2h, repeat procedure ③ and ④.

⑤. Vacuum placing test ..... 1h

⑥. Sketch map of special vacuum dry procedure

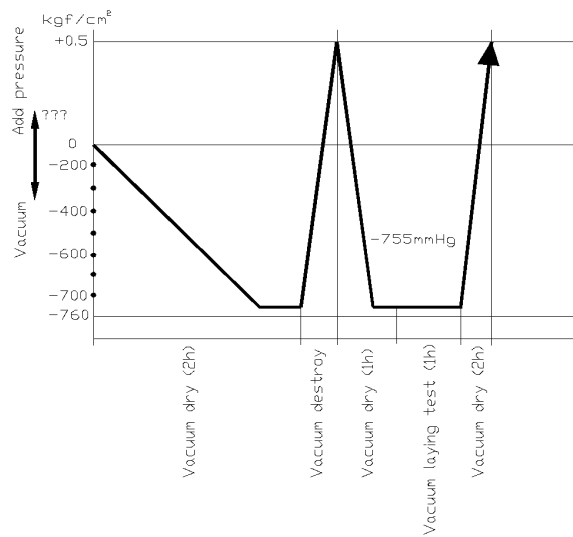



### 3. Additional Refrigerant Charge

#### Caution

- Refrigerant cannot be charged until field wiring has been completed.
- Refrigerant may only be charged after performing the leak test and the vacuum pumping.
- When charging a system, care shall be taken that its maximum permissible charge is never exceeded, in view of the danger of liquid hammer.
- Charging with an unsuitable substance may cause explosions and accidents, so always ensure that the appropriate refrigerant is charged.
- Refrigerant containers shall be opened slowly.
- Always use protective gloves and protect your eyes when charging refrigerant.

The outdoor unit is factory charged with refrigerant. Calculate the added refrigerant according to the diameter and the length of the liquid side pipe of the outdoor unit/indoor unit

R(g) \ L(m) \ D(mm)	φ6.4	Φ9.5	Φ12.7
Less than 5m (One-way)	—	—	—
Added Refrigerant When Over 5m(One-way)	30g/m×(L-5)	65g/m×(L-5)	120g/m×(L-5)

#### Remark:

R (g): Additional refrigerant to be charged

L (m): The length of the refrigerant pipe (one-way)

D (mm): Liquid side piping diameter

## 4. Water Drainage

### 4.1 Gradient and Supporting

4.1.1 Keep the drainpipe sloping downwards at a gradient of at least 1/100. Keep the drainpipe as short as possible and eliminate the air bubble.

4.1.2 The horizontal drainpipe should be short. When the pipe is too long, a prop stand must be installed to keep the gradient of 1/100 and prevent bending. Refer to the following table for the specification of the prop stand.

	Diameter	Distance between the prop stands
Hard PVC pipe	25~40mm	1~1.5m

#### 4.1.3. Precautions

- ① The diameter of drainpipe should meet the drainage requirement at least.
- ② The drainpipe should be heat-insulated to prevent atomization.
- ③ Drainpipe should be installed before installing indoor unit. After powering on, there is some water in water-receiver plate. Please check if the drain pump can operate correctly.
- ④ All connection should be firm.
- ⑤ Wipe color on PVC pipe to note connection.
- ⑥ Climbing, horizontal and bending conditions are prohibited.
- ⑦ The dimension of drainpipe can't less than the connecting dimension of indoor drainpipe.
- ⑧ Heat-insulation should be done well to prevent condensation.
- ⑨ Indoor units with different drainage type can't share one convergent drainpipe.

### 4.2 Drainpipe Trap

4.2.1. If the pressure at the connection of the drainpipe is negative, it needs to design drainpipe trap.

4.2.2. Every indoor unit needs one drainpipe trap.

4.2.3. A plug should be designed to do cleaning.

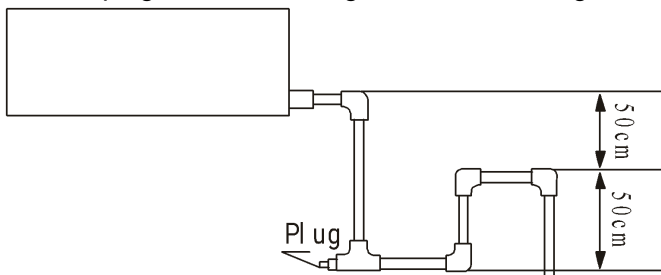

### 4.3 Upwards drainage (drain pump)

Ceiling cassette (compact)

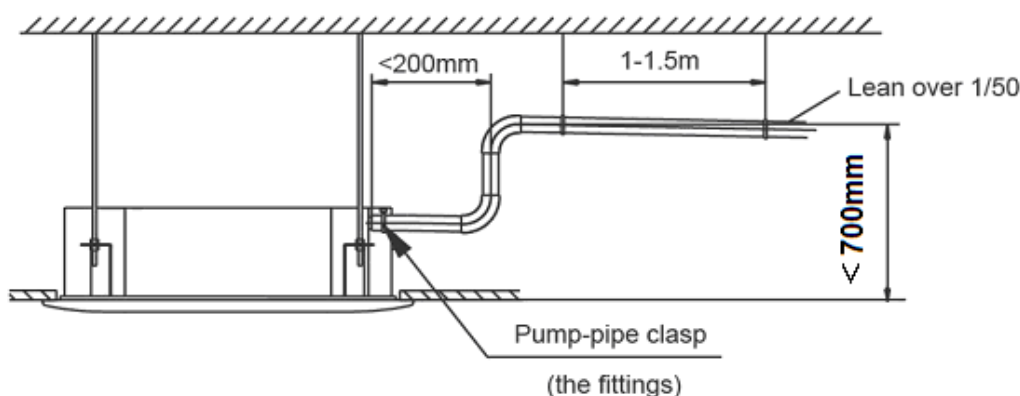

Ceiling cassette

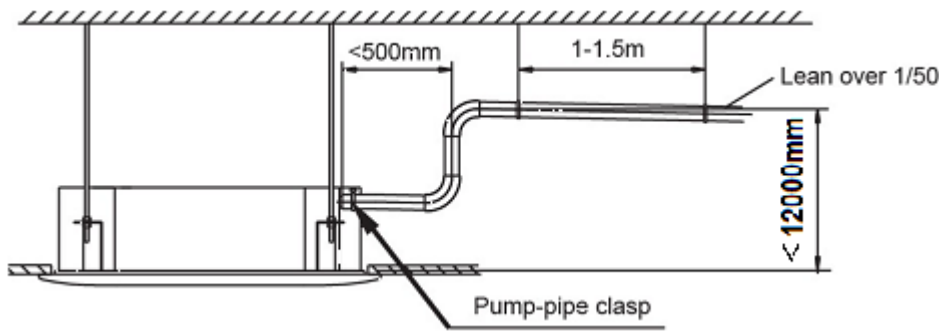

#### 4.4 Convergent drainage

4.4.1. The number of indoor units should be as small as possible to prevent the traverse main pipe overlong.

4.4.2. Indoor unit with drain pump and indoor unit without drain pump should be in different drainage system.



#### 4.4.3. Selecting the diameter

Number of connecting indoor units → Calculate drainage volume → Select the diameter

Calculate allowed volume = Total cooling capacity of indoor units (HP) × 2 (l/hr)

集中排水管	Allowed volume(lean 1/50) (l/hr)	I.D. (mm)	Thick
Hard PVC	$\infty \leq 14$	φ 25	3.0
Hard PVC	$14 < \infty \leq 88$	φ 30	3.5
Hard PVC	$88 < \infty \leq 334$	φ 40	4.0
Hard PVC	$175 < \infty \leq 334$	φ 50	4.5
Hard PVC	$334 < \infty$	φ 80	6.0

#### 4.5 Drainage test

##### 4.5.1 Drainage without drain pump

After finishing drainpipe installation, pour some water into the water receiver plate to check if the water flows smoothly.

##### 4.5.2 Drainage with drain pump

- ① Poke the Water Level Switch, remove the cover, use water pipe to pour 2000ml water into the water receipt plate through the water inlet.

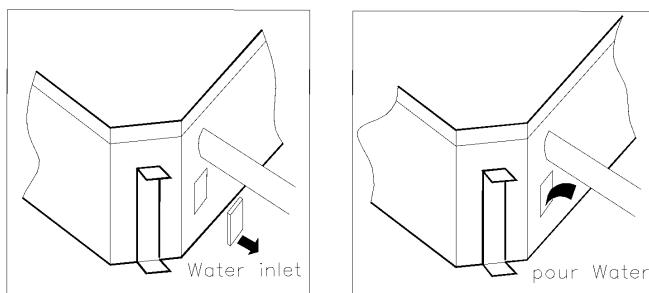

- ② Turn on the power to Cooling operation. Check the pump's operation and switch on the Water Level Switch. Check the pump's sound and look into the transparent hard pipe in the outlet at the same time to check if the water can discharge normally.

③ Stop the air conditioner running, turn off the power, and put back the cover.

- Stop the air conditioner. After 3 minutes, check if it has abnormality. If the collocation of drainpipes is illogical, the water will flow back overfull, which will cause the alarm lamp flashes, even overflow from the water receipt plate.
- Keep on pouring water until it gives an alarm signal for high water level, check if the pump drains water at once. If the water level can't fall below the alarmed water level after 3 minutes, the air conditioner will stop. Turn off the power and drain the remained water, and then turn on the air conditioner.

Note: the drain stuff in the main water receipt plate is for maintenance. Stuff up the drain stuff to prevent water leakage.

## 5. Insulation Work

### 5.1 Insulation material and thickness

#### 5.1.1. Insulation material

Insulation material should adopt the material which is able to endure the pipe's temperature: no less than 70°C in the high-pressure side, no less than 120°C in the low-pressure side (For the cooling type machine, no requirements at the low-pressure side.)

- ◆ Example: Heat pump type----Heat-resistant Polyethylene foam (withstand above 120°C)  
Cooling only type----Polyethylene foam (withstand above 100°C)

#### 5.1.2. Thickness choice for insulation material

Insulation material thickness is as follows:

	Pipe diameter (mm)	Adiabatic material thickness
Refrigerant pipe	Φ6.4—Φ25.4	10mm
	Φ28.6—Φ38.1	15mm
Drainage pipe	Inner diameterΦ20—Φ32	6mm

### 5.2 Refrigerant pipe insulation

#### 5.2.1. Work Procedure

- ① Before laying the pipes, the non-jointing parts and non-connection parts should be heat insulated.
- ② When the gas proof test is eligible, the jointing area, expanding area and the flange area should be heat insulated

#### 5.2.2. Insulation for non-jointing parts and non-connection parts

wrong	right	
Gas pipe and liquid pipe should not be put together to insulate	Insulate the gas pipe (cooling only)	Insulate the gas pipe and liquid pipe

For construction convenience, before laying pipes, use insulation material to insulate the pipes to be deal with, at the same time, at two ends of the pipe, remain some length not to be insulated, in order to be welded and check the leakage after laying the pipes.

#### 5.2.3. Insulate for the jointing area, expanding area and the flange area

- ① Insulate for the jointing area, expanding area and the flange area should be done after checking leakage of the pipes
- ② Make sure there's no clearance in the joining part of the accessorial insulation material and local preparative insulation material.

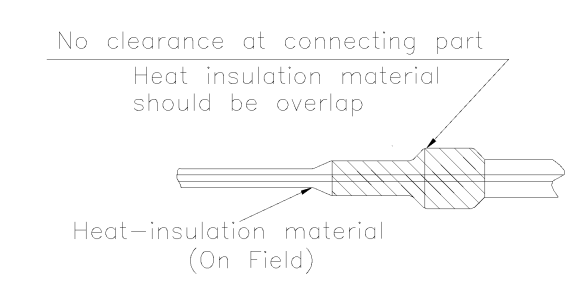

### 5.3 Drainage pipe insulation

The connection part should be insulated, or else water will be condensing at the non-insulation part.

### 5.4 Note

5.4.1 The jointing area, expanding area and the flange area should be heat insulated after passing the pressure test

5.4.2 The gas and liquid pipe should be heat insulated individually, the connecting part should be heat insulated individually.

5.4.3 Use the attached heat-insulation material to insulate the pipe connections (pipes' tie-in ,expand nut ) of the indoor unit

## 6. Test Operation

The indoor unit and outdoor unit are installed properly.

- Tubing and wiring are correctly completed.
- The refrigerant pipe system is leakage-checked.
- The drainage is unimpeded.
- The ground wiring is connected correctly.
- The length of the tubing and the added stow capacity of the refrigerant have been recorded.
- The power voltage fits the rated voltage of the air conditioner.
- There is no obstacle at the outlet and inlet of the outdoor and indoor units.
- The gas-side and liquid-side stop valves are both opened.
- The air conditioner is pre-heated by turning on the power.

**(3) According to the user's requirement, install the remote controller when the remote controller's signal can reach the indoor unit smoothly.**

### **(4) Test operation**

Set the air conditioner under the mode of "COOLING" with the remote controller, and check the following points.

#### **Indoor unit**

- Whether the switch on the remote controller works well.
- Whether the buttons on the remote controller works well.
- Whether the air flow louver moves normally.
- Whether the room temperature is adjusted well.
- Whether the indicator lights normally.
- Whether the temporary buttons works well.
- Whether the drainage is normal.
- Whether there is vibration or abnormal noise during operation.

#### **Outdoor unit**

- Whether there is vibration or abnormal noise during operation.
- Whether the generated wind, noise, or condensed of by the air conditioner have influenced your neighborhood.
- Whether any of the refrigerant is leaked.

## Part 5 Control

<b>1. Wireless Remote Controller</b>	<b>108</b>
<b>2. Wire Controller</b>	<b>113</b>



# 1. Wireless Remote Controller

Instructions of remote controller

“HVAC No.2” remote controller (compatibility with wire controller or lamp board): extension code, applicable to most VRV models.

“HVAC No.3” remote controller (compatibility with wire controller or lamp board): general code, applicable to all models (except of Window machine).

**Warning**

- Do not place remote controller near heat sources such as electric blankets or heating furnaces.
- Do not place remote controller in direct sunlight.
- Be careful not to drop, otherwise it may cause damage.
- No obstacle between the signal receiver and the remote controller, so as not to affect the transmission and reception of the signal.
- Do not splash water or other liquids onto the remote controller.

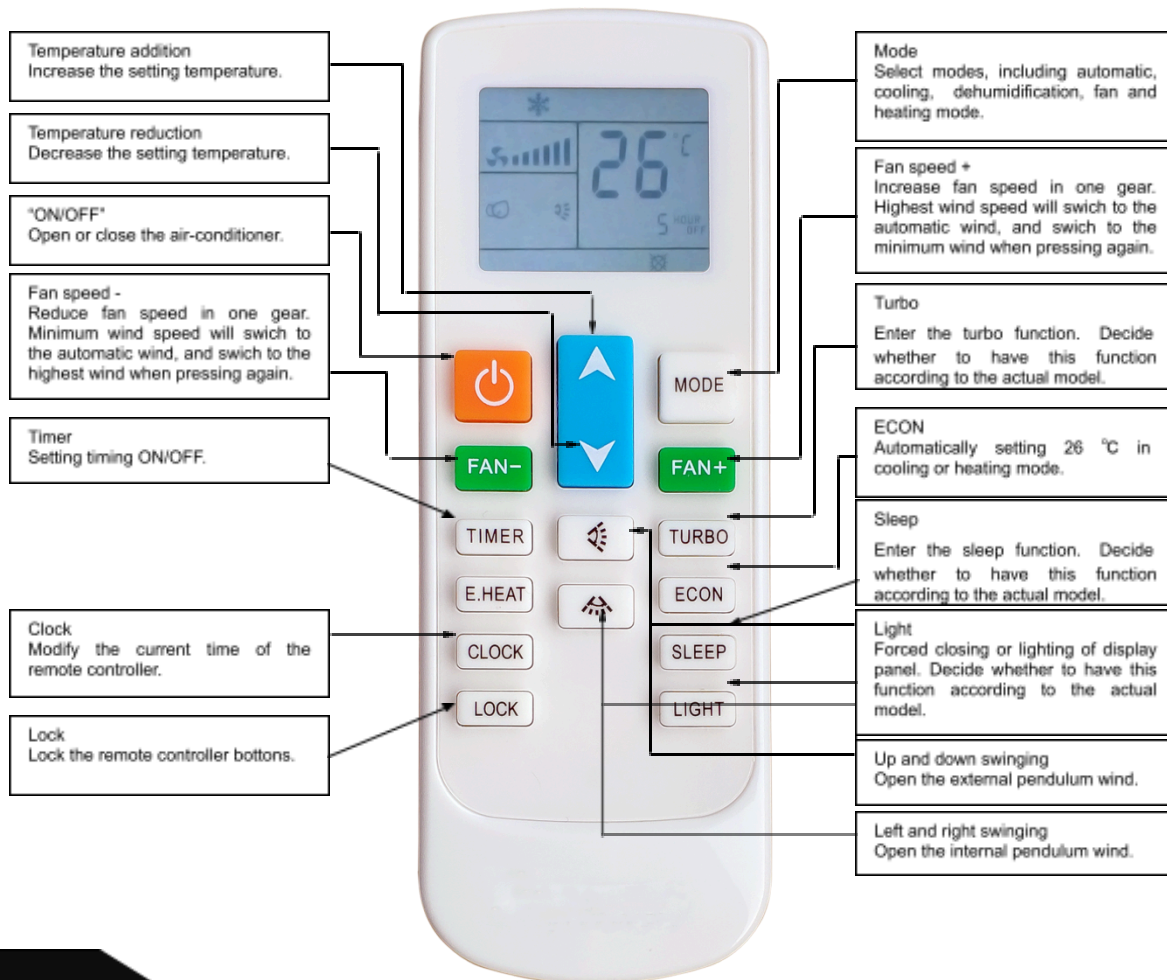

**Warning**

- Point the remote controller to the air conditioner, press the button on the remote controller, and send the command signal to the air conditioner.
- If the signal is received correctly, the air conditioner will issue a "beep" prompt.
- If the remote controller is not available, please replace the new battery and try again. But if the problem persists, please contact the seller or our authorized service center.

The icon meaning of remote controller

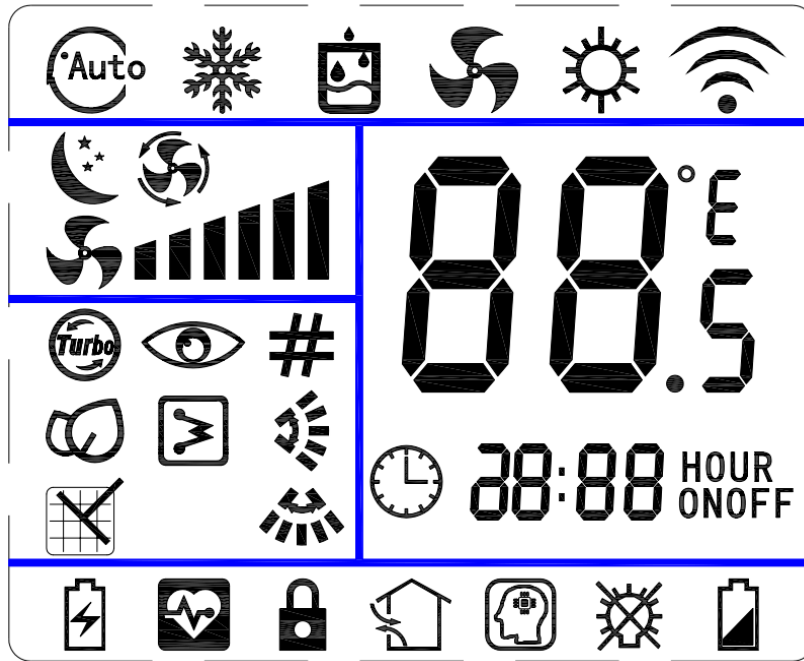









1) The remote controller is equipped with 15 buttons, made with the touch-screen remote controller.

controller is equipped and the LCD is newly icons are kept in touch

2) At the first power on, the LCD of the remote controller displays all the icons first and then enters the standby state, displaying only the clock 12:00 and the light icon.

3) Introduction of LCD screen icon:

Type	Function	Icon
Mode display	fan	
	automatic	
	cooling	
	heating	
	dehumidification	
Temperature display	displays temperature, which range between 16 ~ 32°C or 61 ~ 90°F	
Wind speed display	wind speed	
	automatic wind speed	
Swinging display	external pendulum wind	
	internal pendulum wind.	
Timer display	TIME ON	
	TIME OFF	
Other display	clock	
	sleep	
	TURBO	
	ECON	
	cleaning	

	electric heating	
	address	#
	lock	
	lack of electricity	
Reservation function	Auto Config	
	power saving	
	healthy	
	new wind	
	intelligence	
	lamplight	

Button function of remote controller

### ON/OFF

When pressing this key, the remote controller switches by "on, off, on" circularly.

When the first power on, the working state is set by default: setting temperature 25°C (77°F), automatic mode, automatic fan speed, internal and external pendulum wind, no TURBO, no sleep, no timer, no lock).

When the power on is not the first time, the state before shutdown is recovered. After shutdown, the sleep, TURBO, ECON and timer functions will be canceled.

### Mode

When pressing this key, the remote controller switches by "automatic, cooling, dehumidification, fan, heating, automatic" circularly.

The dehumidification mode is locked at 25°C and the temperature can not be adjusted. The internal pendulum wind stays unchanged according to the state before switching, but the external pendulum wind is forced to close.

### Temperature reduction ▼

Temperature setting: when pressing this key, the setting temperature will be reduced by 1. The temperature of centigrade model will be reduced progressively by "32°C, 31°C, ....., 17°C, 16°C". The temperature of fahrenheit model will be reduced progressively by "90°F, 89°F, ....., 62°F, 61°F". When pressing this key in dehumidification and fan mode, the temperature will not change.

In the clock setting state (the clock icon will flicker to show the prompt), this key is used to set the clock time.

Keep pressing will continuously change the temperature.

### Temperature addition ▲

Temperature setting: when pressing this key, the setting temperature will be added by 1. The temperature of centigrade model will be added progressively by "16°C, 17°C, ....., 31°C, 32°C". The temperature of fahrenheit model will be added progressively by "61°F, 62°F, ....., 89°F, 90°F". When pressing this key in dehumidification and fan mode, the temperature will not change.

In the clock setting state (the clock icon will flicker to show the prompt), this key is used to set the clock time.

Keep pressing will continuously change the temperature.

### Up and down swinging (External pendulum wind)

Pressing this key in the dehumidification mode, the external pendulum wind is forced to close.

Pressing this key in the other modes, the external pendulum switches by "swing, fixed wind, swing" circularly.

### Left and right swinging (Internal pendulum wind)

Pressing this key in the dehumidification mode, the internal pendulum wind stays unchanged according to the state before switching.

Pressing this key in the other modes, the internal pendulum switches by "swing, stop, swing" circularly.

### “FAN .”

When the first power on, the remote controller is set to the automatic wind speed by default. In dehumidification mode, the wind speed is fixed to low wind and is not adjustable. By pressing the wind speed key, there is no response to the remote controller.

Pressing this key in the other modes, the wind speed switches by "automatic wind speed, high speed, middle speed, low speed, automatic wind speed " circularly.

### **“FAN +”**

When the first power on, the remote controller is set to the automatic wind speed by default. In dehumidification mode, the wind speed is fixed to low wind and is not adjustable. By pressing the wind speed key, there is no response to the remote controller.

Pressing this key in the other modes, the wind speed switches by "automatic wind speed, low speed, middle speed, high speed, automatic wind speed " circularly.

### **Timer**

Under the shutdown state, press this key to set the opening time, range from 1 hour to 24 hour.

Under the boot state, press this key to set the shutdown time, range from 1 hour to 24 hour.

The timing time is according to the cycle of "1h, 2h, ....., 23h, 24h, cancel, 1h".

Exit timing adjustment after 3 seconds without key pressing.

### **TURBO**

Extension code remote controller has the effect. The remote controller is no TURBO by default, and the TURBO key will not work in automatic mode, dehumidification mode and fan mode.

Pressing this key in the cooling or heating mode, the TURBO mode switches between opening and closing. When in the TURBO mode, it does not display the wind speed. Switching mode or entering sleep function will close TURBO mode.

If the air conditioner has four gear wind speeds, the TURBO icon will light up and the fan will run in the fourth gear wind speed by pressing this key.

### **ECON**

The remote controller is no ECON by default, and the ECON key will not work in automatic mode, dehumidification mode and fan mode.

Pressing this key in the cooling or heating mode, the ECON mode switches between opening and closing. When in the ECON mode, the setting temperature is set to 26°C (77°F) and other settings are unchanged. If closing ECON mode, the remote controller will recover to the setting before opening ECON mode. Switching mode will close ECON mode.

### **Sleep**

Pressing this key in the modes except of the fan mode, the sleep function switches between opening and closing. Switching mode will cancel sleep function.

When pressing this key, the wind speed is automatically switched to low wind. However, the wind speed can be adjusted according to the wind speed key (except of the dehumidification mode).

### **Light**

When the first power on, there is no lamplight by default. Pressing this key force to turn off or turn on the lamplight. Decide whether to have this function according to the actual model.

### **Clock**

This key is used to set the clock. Pressing enters the hour adjustment state, and the hour digital tube on the LCD is flickering at the same time. The hour can be set by temperature addition or reduction keys, and it ranges from 0 to 23.

When the hour is set, press this key again to enter the minute adjustment state, and the minute digital tube on the LCD is flickering at the same time. The minute can be set by temperature addition or reduction keys, and it ranges from 00 to 59.

After adjusting, press the clock key again to confirm the setting and the adjustment state exits. If do not press the clock key again to confirm, the time adjustment state will exit after 3 seconds, and recover the clock before the adjustment.

### **Lock**

There is no lock by default. Pressing this key, the lock function switches between opening and closing.

When it is locked, the remote controller does not work except the lock key.

### **Combinatorial key: “FAN -” + “FAN +”**

Extension code remote controller has the effect. Switch 3 gear wind and 6 gear wind. There is 6 gear wind on the LCD.

If the 3 gear wind is switched, the first and second gear wind will be "low wind"; the third and fourth gear wind will be "middle wind"; the fifth and sixth gear wind will be "high wind".

### **Combinatorial key: “Mode” + “Lock”**

#### **Enter address setting**

On the shutdown interface, press the combinatorial key on the remote controller for 5 seconds to enter the address setting interface.

The last address (when the first power on, 00 is displayed) and the "#" icon are displayed and flickering.

#### **The step instructions of setting address**

At the address setting interface, press the temperature addition or reduction to adjust the setting address, and it ranges from 00 to 63.

When the first time entering the interface or pressing the temperature addition or reduction key, the address display flickers for 3 seconds and then does not flicker.

Press the ON / OFF key to enter the sending state and send the address setting code.

### The step instructions of inquiring address

At the address setting interface, press the mode key to send the query code.

At this time, the "#" icon flickers. 3 seconds later, it normally displays the last setting addresses and the "#" icon does not flicker.

### Exit setting

Pressing the mode key and lock key at the same time can exit the address setting interface.

If there is no key pressing associated with address setting for more than 30 minutes, the remote controller will exit the address setting interface.

### Battery replacement

1) If the air conditioner is unable to receive the signal from the wire controller, or the LCD of wire controller is blurred, it means that the battery is depleted and needs to be replaced.

2) Take off the back cover and remove the old batteries. When replacing batteries, please pay attention to the "+" and "-" marking on the battery.

3) Install the back cover and set the current time.

### Warning

- Do not mix old and new batteries together.
- When the wire controller is idle for a long time, the battery should be removed.
- In general, the service life of a dry battery that meets the JIS or IEC standards can be up to 6-12 months, but if it exceeds the use time or not in conformity with above specifications, the dry battery may leak and may even cause the wire controller operation to be invalid.
- The recommended service life is marked on the battery, but the actual service life may be shorter.

